

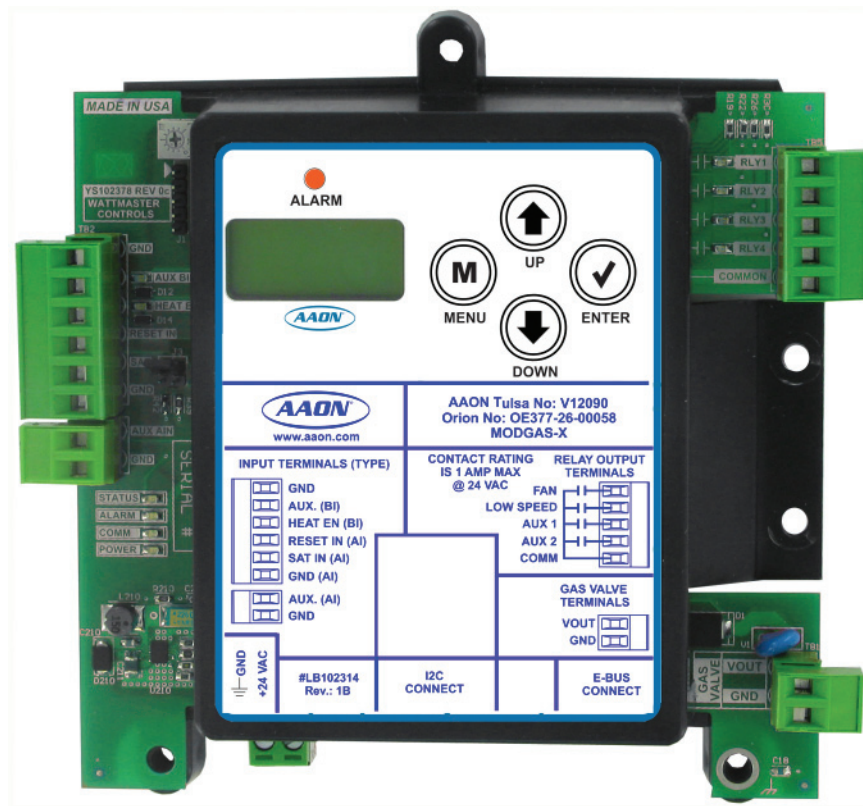

# Factory Packaged Controls

## MODGAS-X Controller Field Technical Guide



# TABLE OF CONTENTS

<b>GENERAL INFORMATION.....</b>	<b>3</b>
Overview .....	3
Features.....	3
<b>INSTALLATION &amp; WIRING.....</b>	<b>4</b>
Important Wiring Considerations.....	4
Single Modulating Valve No Staging.....	5
One Modulating Valve with Up To 14 Fixed Stages .....	7
Two Modulating Staged Valves with Up To 13 Fixed Stages .....	9
Two Modulating Staged Valves.....	11
<b>INPUTS/OUTPUTS.....</b>	<b>13</b>
<b>SEQUENCE OF OPERATIONS.....</b>	<b>14</b>
<b>LCD DISPLAY SCREENS.....</b>	<b>17</b>
<b>TROUBLESHOOTING.....</b>	<b>23</b>
LED Diagnostics .....	23
Troubleshooting Alarms.....	24
Temperature Sensor Testing .....	25
<b>APPENDIX A - Supply Air Temperature Sensor Guide .....</b>	<b>27</b>
Supply Air Temperature Sensor Installation .....	27
Supply Air Temperature Sensor Wiring Chart and Jumper Settings .....	28
<b>APPENDIX B - MODGAS-X Replacement of MODGAS II .....</b>	<b>29</b>
<b>APPENDIX C - MAXITROL® Stepper Valve Types.....</b>	<b>30</b>

PART NUMBER CROSS REFERENCE TABLE		
PART DESCRIPTION	ORION	AAON TULSA
MODGAS-X Controller	OE377-26-00058	V12090
MODGAS-X Low Turn Down Controller	OE377-26-00058-1	V12091
MHGRV-X Controller	OE377-26-00059	V12100
MHGRV II Controller	OE377-00-00042	R12190
MHGRV III Controller	OE377-00-00054	R71830
Supply Air Temperature Sensor	OE231	P87140



AAON, Inc.  
 2425 South Yukon Ave.  
 Tulsa, OK 74107-2728  
 www.aaon.com  
 Factory Technical Support Phone: 918-382-6450  
 Controls Support Phone: 866-918-1100  
 Form: AA-MODGASX-FIELD-TGD-01H

AAON Part Number: V16940, Rev. 01H  
 All rights reserved. © October 2018 AAON, Inc.  
 AAON® assumes no responsibility for errors or omissions in this document.  
 AAON® is a registered trademark of AAON, Inc., Tulsa, OK.  
 MAXITROL® is a registered trademark of Maxitrol, Inc., Southfield, MI  
 This document is subject to change without notice.

**Overview**

The OE377-26-00058 MODGAS-X Controller (AAON Part No. V12090) is designed to modulate up to (2) gas valves to maintain a desired Discharge Air Temperature. The MODGAS-X Controller also controls the speed of the induced draft fan to maintain proper combustion in the heat exchanger. See **Figure 1** for dimensions.

The controller can be used as a stand-alone controller or communicating with an AAON Unit Controller. The MODGAS-X controller connects to an AAON unit controller or expansion module via a modular cable. Depending on the type of unit controller, this connection will utilize an I<sup>2</sup>C connection or an E-BUS connection. See **page 5** for wiring details.

The MODGAS-X Controller can be configured at the factory for one (1) modulating valve, two (2) staged modulating valves, or one (1) or two (2) modulating with multiple fixed staged valves (stand-alone operation only).

The MODGAS-X Controller can be configured at the factory for the MAXITROL® 0-20 volt valve(s) or the MAXITROL® EXA STAR 0-10 volt stepper valve(s). See **Appendix C, page 30** for depiction.

When using the MODGAS-X Controller to replace an existing MODGAS II Controller, see **Appendix B, page 29** for details.

**Features**

The MODGAS-X Controller provides the following:

- Monitors Supply Air Temperature and Supply Air Reset and modulates gas valve(s) to maintain Setpoint
- Provides proper control of the Induced Draft Fan
- Provides additional options for Stand-Alone control
- Contains a 2 x 8 LCD character display and 4 buttons that allow for status display, setpoint changes, and force modes

**NOTE:** The MODGAS-X Controller contains no user-serviceable parts. Contact qualified technical personnel if your MODGAS-X Controller is not operating correctly.

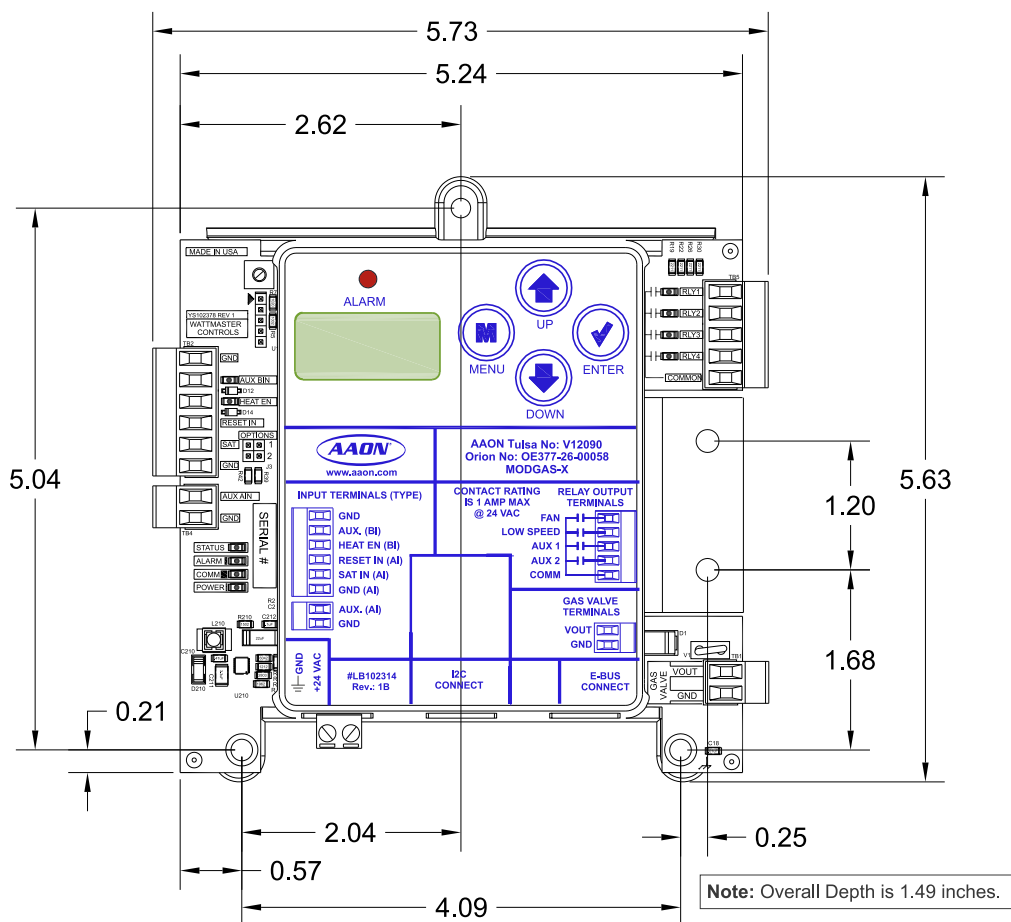

**Figure 1: MODGAS-X Controller Dimensions (In Inches)**

## Important Wiring Considerations

---

### Important Wiring Considerations

Please read carefully and apply the following information when wiring the MODGAS-X Controller. The MODGAS-X Controller requires the following electrical connections:

1. 18 gauge minimum wire unless otherwise noted.
2. 24 VAC power connection with an appropriate VA rating.
3. Supply Air Temperature Sensor and Heat Enable must have 24 gauge minimum wire.
4. All 24 VAC wiring must be connected so that all ground wires remain common. Failure to follow this procedure can result in damage to the module and connected devices.
5. All wiring is to be in accordance with local and national electrical codes and specifications.
6. Check all wiring leads at the terminal block for tightness. Be sure that wire strands do not stick out and touch adjacent terminals. Confirm that all transducers required for your system are mounted in the appropriate location and wired into the correct terminals.

---

---

**WARNING:** Do Not Connect Power To VOUT/Ground Terminal Block!

---

---

---

---

**WARNING:** Observe polarity! All boards must be wired GND-to-GND and 24 VAC-to-24 VAC. Failure to observe polarity could result in damage to the board.

---

---

# Single Modulating Valve No Staging - Stand-Alone Wiring

## Single Modulating Valve No Staging - Stand-Alone Wiring

This configuration operates as Stand-Alone (Figure 2, below) or communicating with an AAON Unit Controller (Figure 3, page 6).

This configuration can use either the MAXITROL® 0-20 volt valve(s) or the MAXITROL® EXA STAR 0-10 volt stepper valve(s)—configured at the factory. See Appendix C, page 30 for depiction.

If using a MHGRV-X Controller along with the MODGAS-X Controller in Stand-Alone, the SAT Sensor always connects to the MODGAS-X Controller.

**WARNING:** Do Not Connect Power To VOUT/Ground Terminal Block!

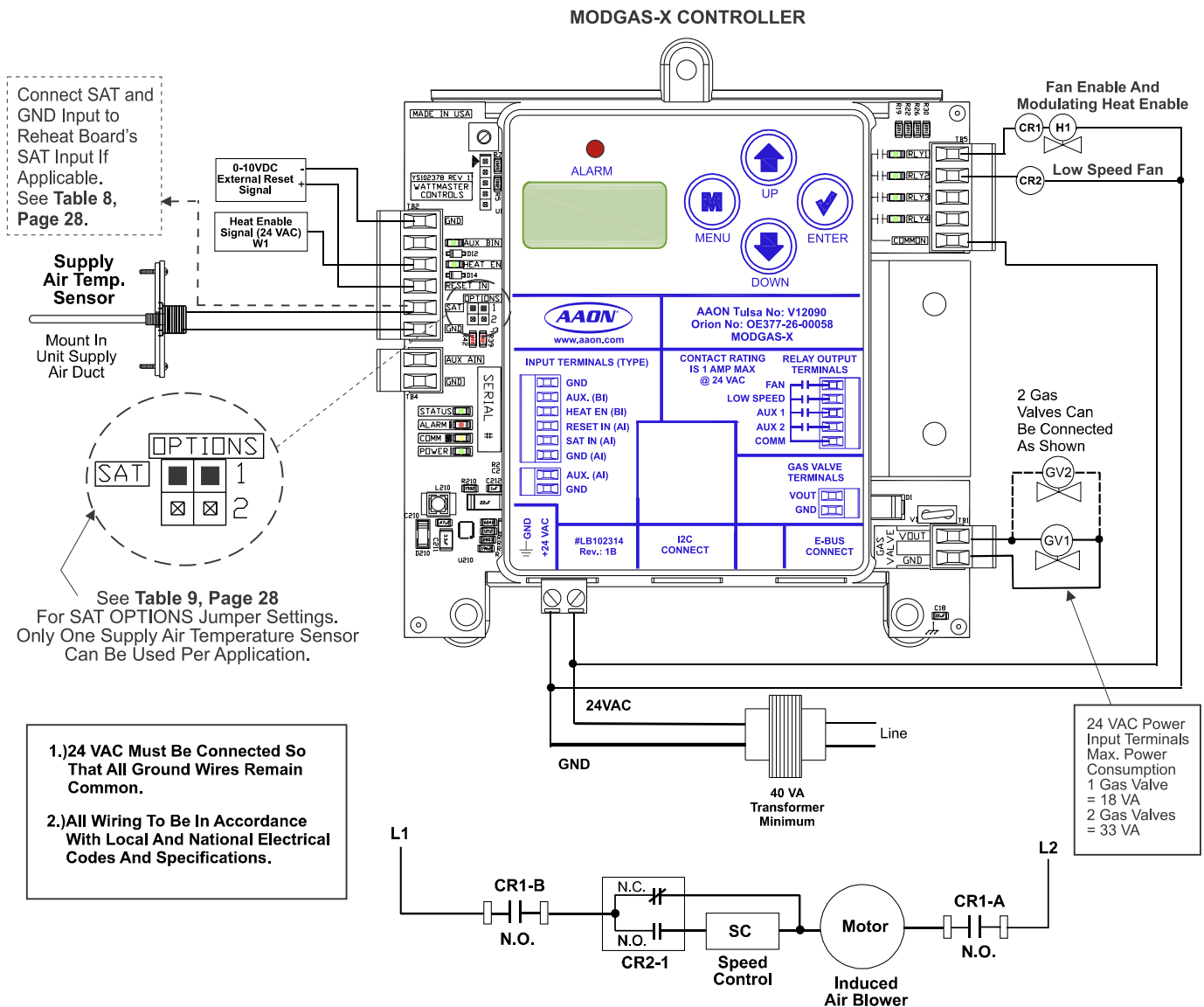

Figure 2: Single Modulating Valve No Staging Stand-Alone Wiring Diagram

# WIRING

## Single Modulating Valve No Staging - Communicating Wiring

### Single Modulating Valve No Staging - Communicating Wiring

This configuration operates as Stand-Alone (Figure 2, page 5) or communicating with an AAON Unit Controller (Figure 3, below).

For connection to a VCCX2 or VCB-X Controller or VCCX2 or VCB-X Expansion Module, use an E-BUS Cable connecting to the appropriate E-BUS ports on those controllers. For all other controllers, including VAV/CAV, MUA, VCM, VCM-X, SA, and RNE Controllers, use an I<sup>2</sup>C Cable connecting to the appropriate I<sup>2</sup>C ports on those controllers.

This configuration can use either the MAXITROL® 0-20 volt valve(s) or the MAXITROL® EXA STAR 0-10 volt stepper valve(s)—configured at the factory. See Appendix C, page 30 for depiction.

**WARNING:** Do Not Connect Power To VOUT/Ground Terminal Block!

**NOTE:** If additional fixed stages are required, these should be configured and wired to the AAON Unit Controller's relays.

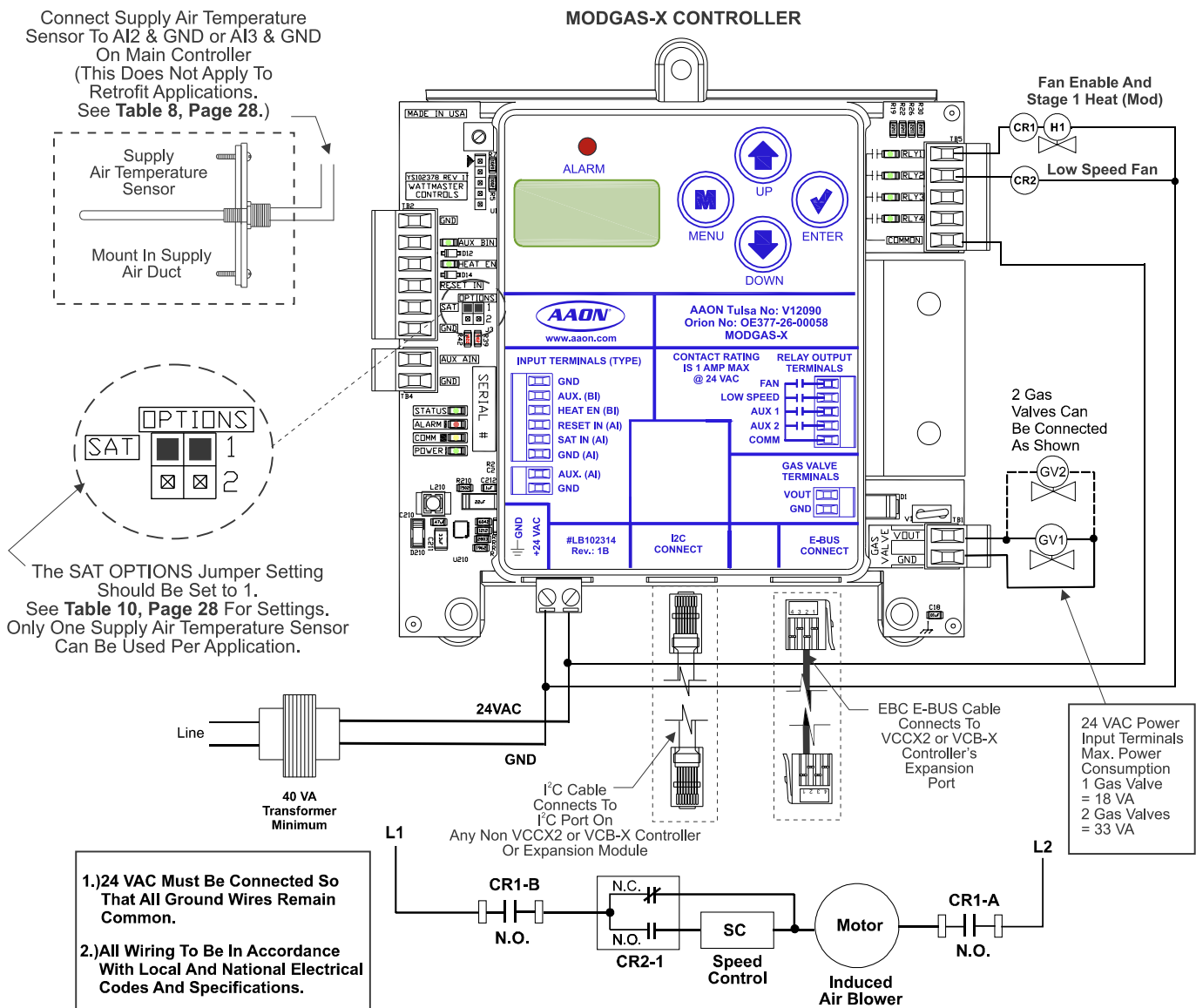

Figure 3: Single Modulating Valve No Staging Communicating Wiring Diagram

# Single Modulating Valve & Up To 14 Stages Fixed Heat Stand-Alone

## One Modulating Valve With Up To 14 Additional Stages Of Fixed Heat Stand-Alone Wiring

This configuration only applies to a Stand-Alone operation (Figure 4, below) and is factory-configured.

If using a MHGRV-X Controller along with the MODGAS-X Controller in Stand-Alone, the SAT Sensor always connects to the MODGAS-X Controller.

The first two fixed stages use AUX1 and AUX2 relays to enable them (Figure 4, below). Additional fixed stages can be added by using the 12-Relay E-BUS Expansion Module. (Figure 5, page 8).

This configuration can use either the MAXITROL® 0-20 volt valve(s) or the MAXITROL® EXA STAR 0-10 volt stepper valve(s) (configured at the factory). See Appendix C, page 30 for depiction.

**WARNING:** Do Not Connect Power To VOUT/Ground Terminal Block!

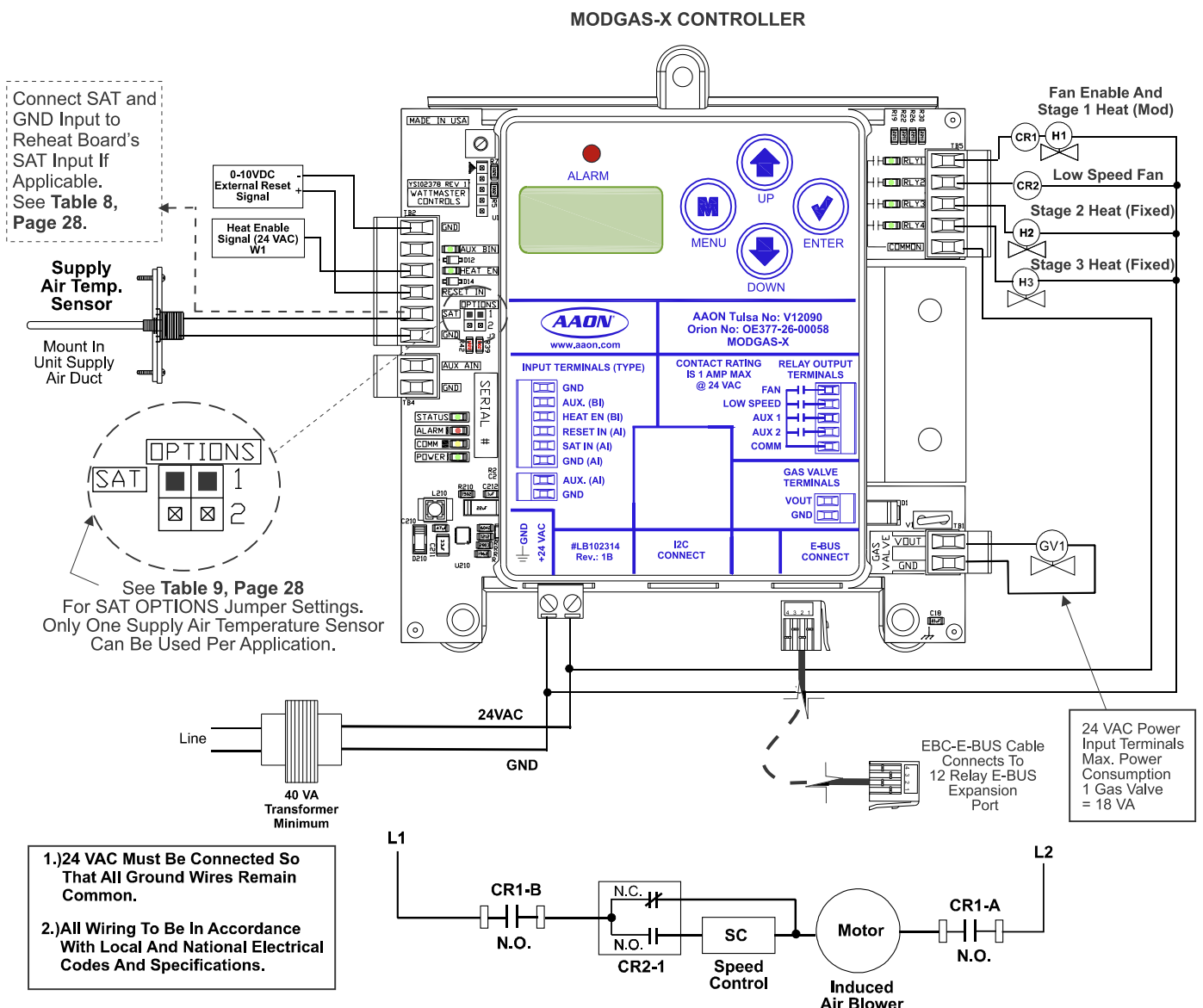

Figure 4: Single Modulating Valve - Stand-Alone

# WIRING

## Single Modulating Valve & 14 Stages of Fixed Heat - Stand-Alone

### One Modulating Valve With Up To 14 Additional Stages Of Fixed Heat Stand-Alone Wiring, Continued

the MODGAS-X Controller will alarm and fall back to using only its onboard stages. If communications is restored, the MODGAS-X Controller will begin staging up if needed.

If communication is lost to the 12-Relay E-BUS Expansion Module, the 12-Relay E-BUS Expansion Module will turn off its relays and

#### WARNING!!

Observe Polarity! All boards must be wired with GND-to-GND and 24VAC-to-24VAC. Failure to observe polarity will result in damage to one or more of the boards. Expansion Modules must be wired in such a way that the expansion modules and the controller are always powered together. Loss of power to the expansion module will cause the controller to become inoperative until power is restored to the expansion module.

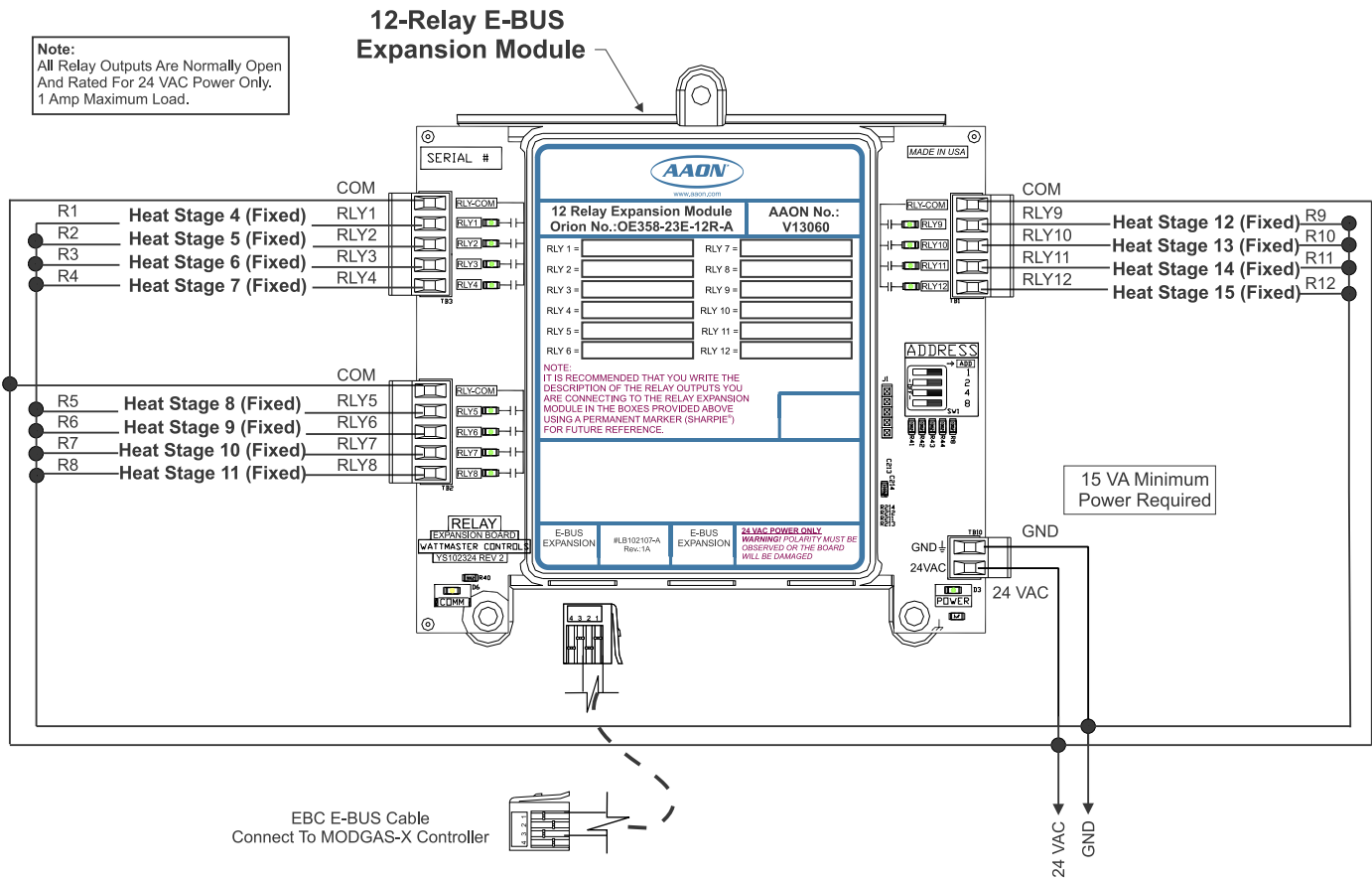

Figure 5: Single Modulating Valve & 14 Stages of Fixed Heat - 12-Relay E-BUS Expansion Module



# Two Modulating Valves & Up To 13 Stages Fixed Heat Stand-Alone

## Two Modulating Valves With Up To 13 Additional Stages Of Fixed Heat Stand-Alone Wiring

This configuration only applies to a Stand-Alone operation (Figure 6, below) and is factory-configured.

In this configuration, the first Modulating Valve is enabled by the FAN RLY. The second Modulating Valve is enabled by the AUX1 relay. The fixed stage uses the AUX2 relay to enable it (Figure 6, below). Additional fixed stages can be added by using the 12-Relay E-BUS Expansion Module. (Figure 7, page 10).

If using a MHGRV-X Controller along with the MODGAS-X Controller in Stand-Alone, the SAT Sensor always connects to the MODGAS-X Controller.

This configuration can use either the MAXITROL® 0-20 volt valve(s) or the MAXITROL® EXA STAR 0-10 volt stepper valve(s) (configured at the factory). See Appendix C, page 30 for depiction.

**WARNING:** Do Not Connect Power To VOUT/Ground Terminal Block!

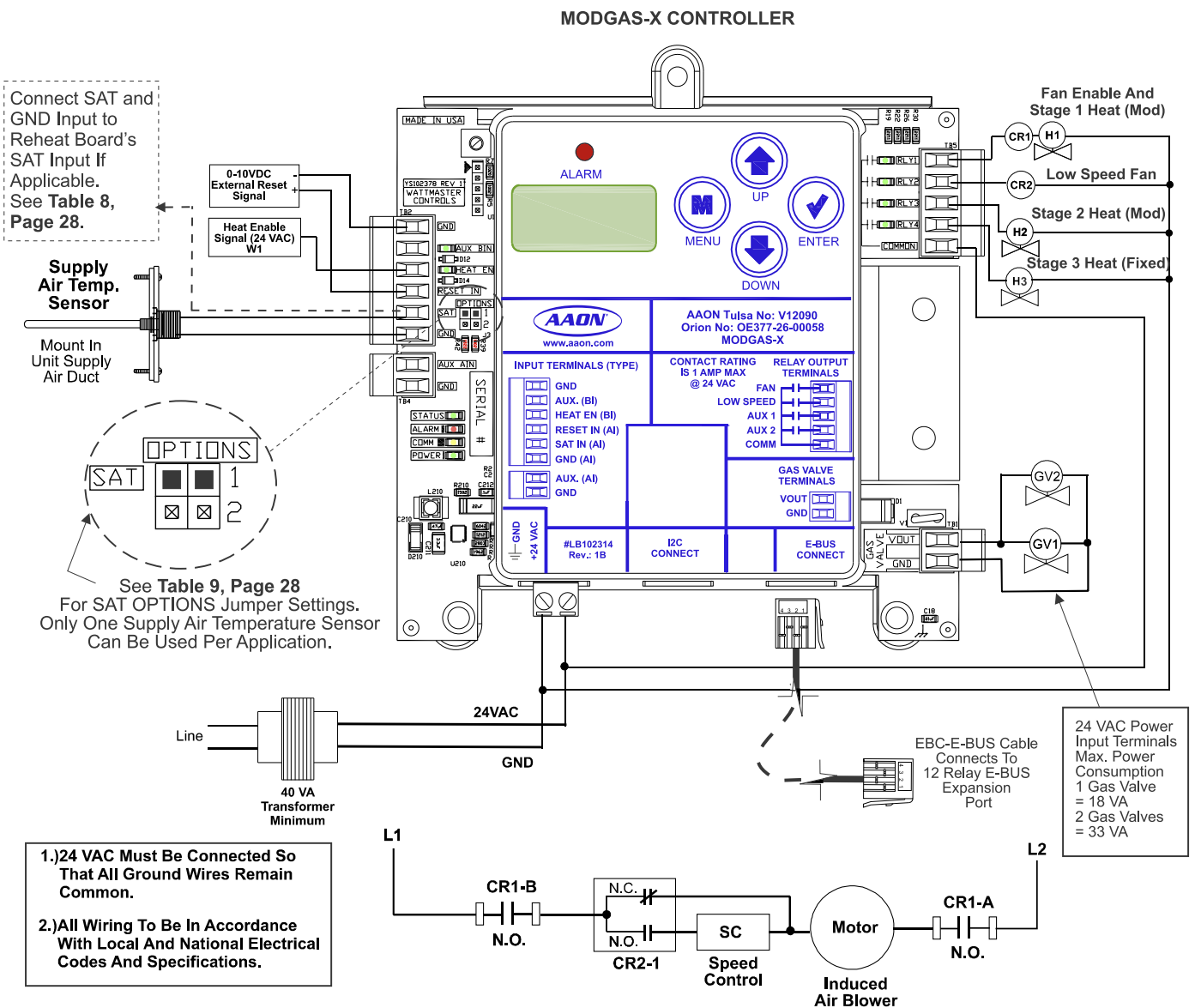

Figure 6: Two Modulating Valves - Stand-Alone

# WIRING

## Two Modulating Valves & Up To 13 Stages Fixed Heat - Stand-Alone

### Two Modulating Valve With Up To 13 Additional Stages Of Fixed Heat Stand-Alone Wiring, Continued

the MODGAS-X Controller will alarm and fall back to using only its onboard stages. If communications is restored, the MODGAS-X Controller will begin staging up if needed.

If communication is lost to the 12-Relay E-BUS Expansion Module, the 12-Relay E-BUS Expansion Module will turn off its relays and

#### WARNING!!

Observe Polarity! All boards must be wired with GND-to-GND and 24VAC-to-24VAC. Failure to observe polarity will result in damage to one or more of the boards. Expansion Modules must be wired in such a way that the expansion modules and the controller are always powered together. Loss of power to the expansion module will cause the controller to become inoperative until power is restored to the expansion module.

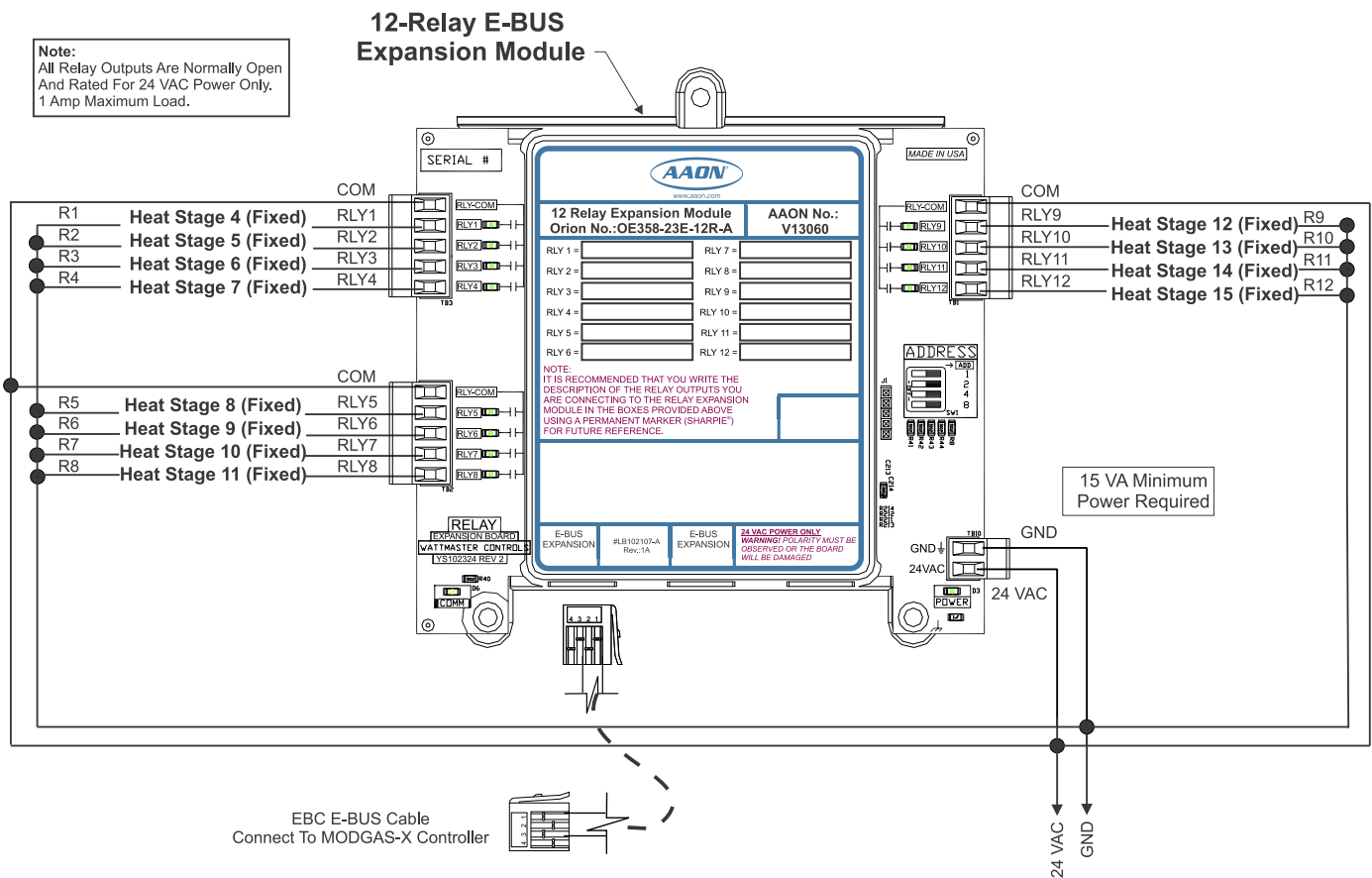

Figure 7: Two Modulating Valves & 13 Stages of Fixed Heat - 12-Relay E-BUS Expansion Module

## Two Modulating Staged Valves - Stand-Along Wiring

### Two Modulating Staged Valves Wiring

In this configuration, the first Modulating Valve is enabled by the FAN RLY. The second Modulating Valve is enabled by the AUX1 relay.

This configuration operates as Stand-Along (Figure 8, below) or communicating with an AAON Unit Controller (Figure 9, page 12).

If using a MHGRV-X Controller along with the MODGAS-X Controller in Stand-Along, the SAT Sensor always connects to the MODGAS-X Controller.

This configuration can use either the MAXITROL® 0-20 volt valve(s) or the MAXITROL® EXA STAR 0-10 volt stepper valve(s)—configured at the factory. See Appendix C, page 30 for depiction.

**WARNING:** Do Not Connect Power To VOUT/Ground Terminal Block!

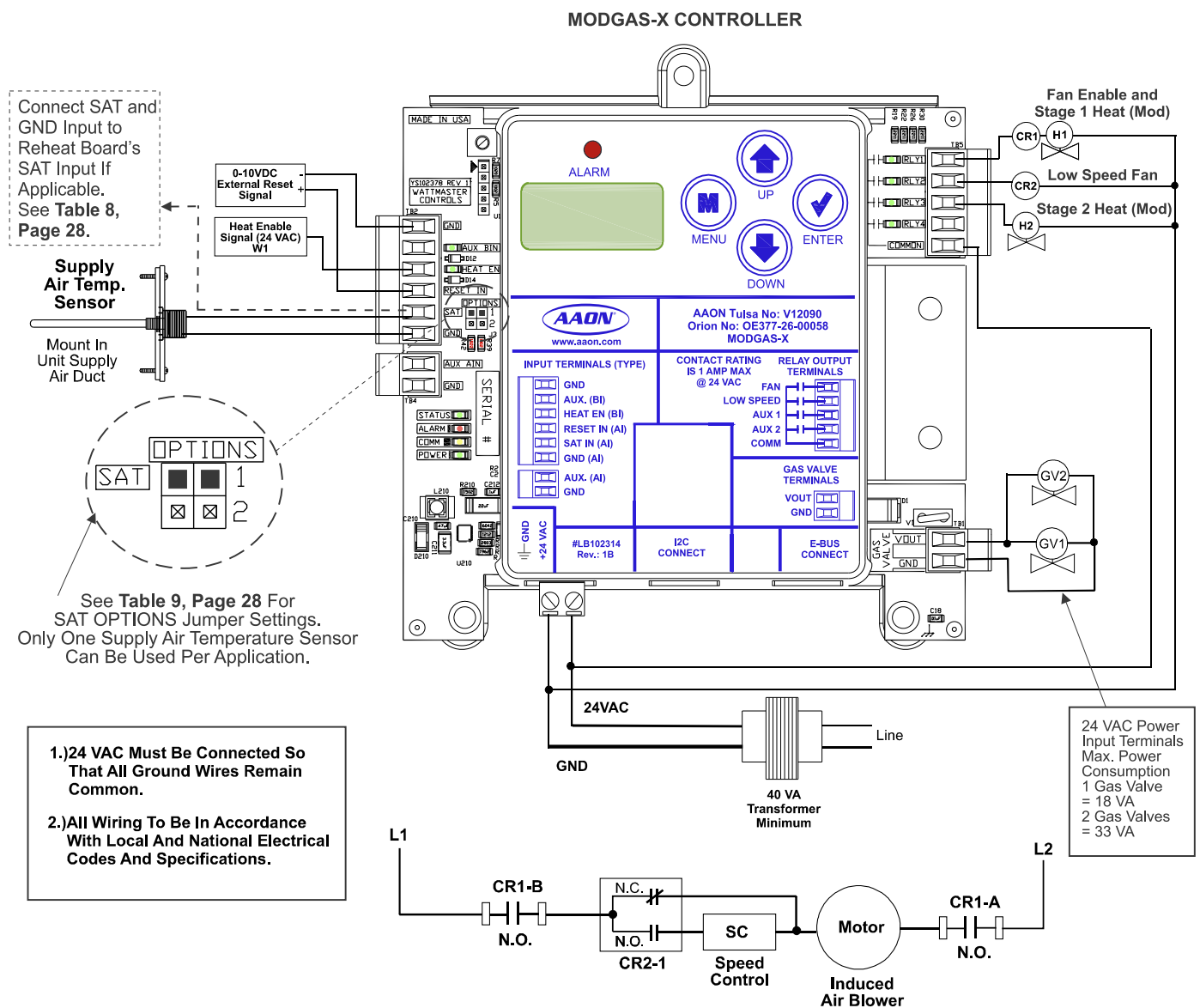

Figure 8: Two Modulating Staged Valves Stand-Along Wiring Diagram

## Two Modulating Staged Valves - Communicating Wiring

### Two Modulating Staged Valves - Communicating Wiring

This configuration operates as Stand-Alone (Figure 8, page 11) or communicating with an AAON Unit Controller (Figure 9, below).

For connection to a VCCX2 or VCB-X Controller or VCCX2 or VCB-X Expansion Module, use an E-BUS Cable connecting to the appropriate E-BUS ports on those controllers.

For all other controllers, including VAV/CAV, MUA, VCM, VCM-X, SA, and RNE Controllers, use an I<sup>2</sup>C Cable connecting to the appropriate I<sup>2</sup>C ports on those controllers.

If using the VCM-X Controller (I<sup>2</sup>C), extra fixed stages can be added by using the VCM-X Expansion Module.

This configuration can use either the MAXITROL® 0-20 volt valve(s) or the MAXITROL® EXA STAR 0-10 volt stepper valve(s) (configured at the factory). See Appendix C, page 30 for depiction.

**WARNING:** Do Not Connect Power To VOUT/Ground Terminal Block!

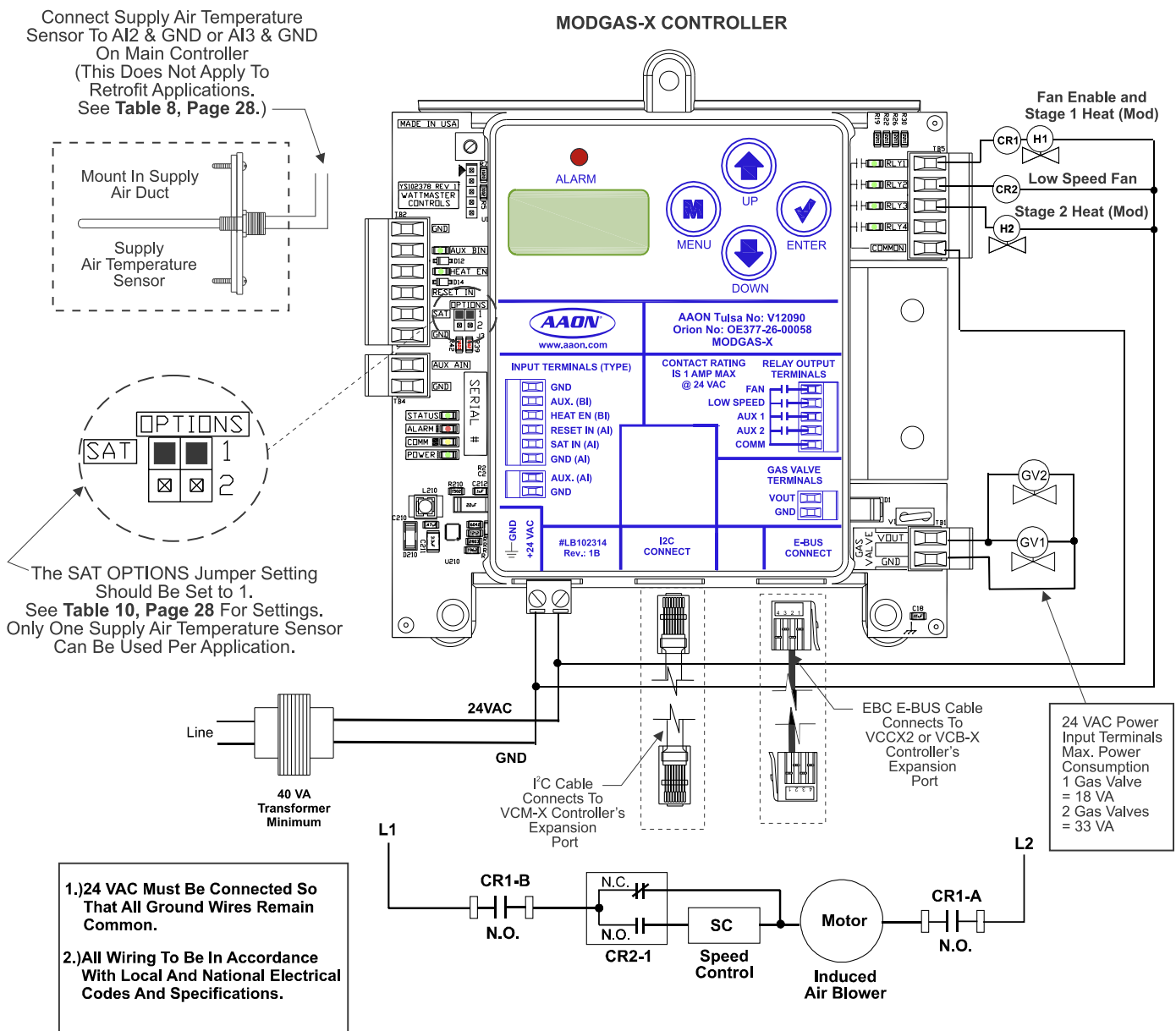

Figure 9: Two Modulating Staged Valves Communicating Wiring Diagram

### I/O Map

See **Table 1** below to reference the inputs and outputs that are available on the MODGAS-X Controller.

Analog Inputs	
1	(RST IN) Reset Signal
2	(SAT) Supply Temperature
3	(AUX AI) Not Used
Binary Inputs	
1	(AUX BI) Not Used
2	(HEAT EN) Heat Enable
Analog Output (0-20 or 0-10 VDC)	
1	(VOUT) Heat Valve
Relays	
1	(FAN) Fan and Stage 1 Heat (Modulating)
2	(LOW SPEED) Low Speed Fan
3	(AUX 1) Stage 2 Heat (Fixed or Modulating)
4	(AUX 2) Stage 3 Heat (Fixed or Modulating)

**Table 1: MODGAS-X Controller Inputs & Outputs**

### Analog Inputs

#### Reset Input (RST IN)

Used only in stand-alone operation. The Discharge Temperature Setpoint can be reset by supplying a 0-10 VDC signal to the RST IN low voltage terminal block. This reset signal is optional and need only be used if you require resetting of the discharge air temperature.

#### Supply Air Temperature Sensor (SAT)

Used in stand-alone operation and when MODGAS-X is connected to a CAV/VAV or MUA Controller. The Supply Air Temperature Sensor is the control source. This sensor has to be installed for the unit to operate. The Supply Air Sensor is located in the discharge air stream and monitors discharge air temperature to maintain the discharge air temperature setpoint.

### Binary Inputs

#### Heat Enable Contact (HEAT EN)

This input is only required when the controller is used in stand-alone operation; it is not required when communicating with an AAON Unit Controller. The Heat Enable input is activated by a 24VAC signal supplied from a building automation system to enable the MODGAS-X Controller. The controller will not operate without 24VAC being applied to this input terminal when used in a stand-alone configuration. When the Heat Enable signal is lost or turned off, all stages de-activate immediately.

This enable input can be used in communication mode for special circumstances. Heat enable can be activated by either communications or this enable input. Heat enable will be deactivated when both signals from communications and the enable input is turned off.

### Analog Output

#### Gas Valve Output (VOUT)

Depending on the type of valve used, this output will supply a 0-20 VDC or 0-10 VDC output signal for control of the modulating gas valve. With a 0-20 VDC valve, the operation is reverse acting, so high voltage means closed and low voltage means open. With a 0-10 VDC valve, the operation is direct acting.

**WARNING:** For 0-20 VDC valves, the maximum number that can be connected/configured is 2. For 0-10 VDC valves, the maximum number that be can connected/configured is 8.

### Relay Outputs

#### Relay #1 - Fan and Stage 1 Heat Modulating

When the MODGAS-X Controller has heat enabled, this relay closes to bring the induced draft blower on at high speed. The controller will activate the Low Speed Fan Relay to reduce the induced draft blower speed as the gas valve modulates closed. This relay is also used to enable Modulating Heat Valve 1.

#### Relay #2 - Low Speed Fan

Depending on the gas valve position, this relay will close to switch the induced draft blower to low speed. The controller automatically switches the blower to low speed as the gas valve modulates closed in order to maintain the proper fuel to air ratio.

## Outputs and Operation Modes

### Relay #3 - Aux 1

**Stage 2 Heat (Fixed or Modulating)**—If configured for two or more stages of heat, this relay would enable the 2nd stage of heat if the 1st modulating valve cannot maintain the configured supply air temperature setpoint. This stage and any additional stages of heat will stage up and down as required to maintain the Supply Air Temperature Setpoint. The Stage Up Delay default is 3 minutes. The Stage Down Delay default is 1 minute.

### Relay #4 - Aux 2

**Stage 3 Heat (Fixed or Modulating)**—If configured for three or more stages of heat, this relay would enable the 3rd stage of heat as needed to maintain the configured supply air temperature setpoint. This stage and any additional stages of heat will stage up and down as required to maintain the Supply Air Temperature Setpoint. The Stage Up Delay default is 3 minutes. The Stage Down Delay default is 1 minute.

### 12-Relay E-BUS Expansion Module - Stand-Alone Only

**Stages 4-15 Heat (Fixed)** These relays should only be used in Stand-Alone configuration when more than three stages of heat are configured. These relays will successively stage up based on the stage up delay to maintain the configured supply air temperature setpoint. This stage and any additional stages of heat will stage up and down as required to maintain the Supply Air Temperature Setpoint. The Stage Up Delay default is 3 minutes. The Stage Down Delay default is 1 minute.

### Operation Modes

The MODGAS-X Controller can be used stand-alone or communicating with an AAON Unit Controller using a modular cable.

#### Stand-Alone Mode

When used in a stand-alone application, the MODGAS-X Controller will modulate the gas valve(s) and stage any additional fixed stages to maintain the DISCHARGE setpoint configured on the MODGAS-X Controller LCD display. The MODGAS-X Controller is activated by a 24VAC signal to the HEAT EN input.

The following are available in Stand-Alone mode using the LCD display on the MODGAS-X Controller:

- **Status**
- **Supply Air Temperature Setpoint Adjustment**
- **Supply Air Reset Temperature Setpoint Adjustment**
- **Force Mode ON/OFF**
- **Force Valve Position**
- **Force Relays**
- **Alarms**

#### Communicating Mode

When the MODGAS-X Controller is connected and communicating with an AAON Unit Controller via a modular cable, the necessary information will be passed between the MODGAS-X and the Main Unit Controller to properly operate in the Heating Mode.

If the communication is interrupted between the MODGAS-X Controller and the Main Controller, both boards will show an alarm. When communication is restored, the alarms will go away.

In this configuration, the Supply Air Temperature Setpoint is set using the Main Controller and the Supply Air Temperature Reset is calculated by the Main Controller.

The following are available in communicating mode using the LCD display on the MODGAS-X Controller:

- **Status**
- **Force Mode ON/OFF**
- **Force Valve Position**
- **Force Relays**
- **Alarms**

### Normal Operation

The MODGAS-X Controller modulates up to (2) gas valves (for 0-20 volt valves) or (8) gas valves (for 0-10 volt valves) to maintain a desired Discharge Air Temperature. It also controls the speed of the induced draft fan to maintain proper combustion in the heat exchanger.

### Off Mode

1. If the Heating is disabled, the unit will be in the Off Mode.
2. In this mode, the unit will be completely shut off.
3. The Heat Valve Output will be set to 100%.
4. Once the unit enters the Off Mode, it will stay in this mode for at least 1 minute.

### High Fire Mode

1. When Heat is activated, the unit will first go to High Fire Mode.
2. In this mode, the valve will be forced to 100%—for a 0-20 volt valve, that would be 0 VDC and for a 0-10 volt valve, that would be 10 VDC—and the Fan relay will be activated.
3. The unit will stay in this mode for at least 10 seconds.
4. After the initial 10 seconds, the unit will look for a 3°F temperature rise from the initial Supply Air Temperature during Stage 1 and will look for a 5°F temperature rise from the Supply Air Temperature during additional Modulating Heat stages to exit the High Fire Mode.
5. The unit could stay in High Fire Mode indefinitely if it does not see the temperature rise. This is important because it means that the unit has not seen proof of fire and starting modulation without proof could cause damage to the equipment.
6. The Low Speed relay will not be activated during High Fire Mode.

### Mechanical Failure Alarm

**Note:** This alarm was removed in version 3.06.

1. The Mechanical Failure Alarm will be enabled when the unit stays in High Fire Mode for more time than the Mechanical Failure Delay Setpoint—setpoint default is 4 minutes.
2. The Alarm is disabled when the failed Heat Stage goes to Off Mode.

### Heating Mode

1. Once the controller finalizes High Fire Mode, it will go to Heating Mode.
2. In this mode, a unit with a 0-20 volt valve will modulate between 25% (15VDC) to 75% (5VDC) of the value range (which is displayed as 0-100%) to maintain the desired Supply Air Setpoint. (See Table 2.)
3. The Supply Air Setpoint is sent by the Main Controller when in communicating mode, or is set in the Setpoint screens through the LCD display when in stand-alone operation.
4. Once the unit enters the Heating Mode, it will stay in this mode for the minimum runtime—default is 1 minute.
5. The Unit will exit the Heating Mode when the 24 VAC Heat Enable signal is removed or the Heat command from the unit controller is removed.

HEATING MODE VOLTAGE / SIGNAL		
0-20 VOLT VALVE		
LCD DISPLAY	VOLTAGE	SIGNAL
0%	15 Volts	25%
100%	5 Volts	75%
0-10 VOLT STEPPER VALVE		
LCD DISPLAY	VOLTAGE	SIGNAL
0%	0 Volts	0%
100%	10 Volts	100%

**Table 2: Heating Mode Voltage / Signal**

### Low Speed Relay Operation

#### 0-20 Volt Valve

1. If the valve modulates below 54.5% (9.1VDC) for 5 seconds, the Low Speed Relay will be activated.
2. The Low Speed relay will be deactivated if the valve modulates above 55.5% (8.9VDC) for 5 seconds.

#### 0-10 Volt Valve

1. If the valve modulates below 33% (3.3VDC) for 5 seconds, the Low Speed Relay will be activated.
2. The Low Speed relay will be deactivated if the valve modulates above 34% (3.4VDC) for 5 seconds.

---

## Sequence of Operation

---

### Additional Stages of Heat

If the MODGAS-X is controlling more than one Stage of Heat, it will use the following staging sequence:

1. If the ModGas valve signal is at 100% for 3 minutes (adjustable), the Aux Relays will stage up. If the Supply Air Temperature is 32° or less, the stage up delay will reset to 1 minute.
2. If the ModGas valve signal is at 0% for 1 minute (adjustable), the Aux Relays will stage down.
3. As the Aux Relays stage up/down, the ModGas valve will modulate as necessary to maintain setpoint.

### Supply Air Setpoint Reset

1. In stand-alone operation, the controller will look at the voltage of the Reset Signal to provide a setpoint reset mechanism. This input is expecting a 0-10VDC signal.
2. When the Signal is at 0VDC, the setpoint will be equal to the SAT setpoint set in the LCD display.
3. When the Signal is a 10VDC, the setpoint will be equal to the Reset setpoint set in the LCD display.
4. The setpoint value will be reset proportionally from the value set in the LCD display as the signal goes from 0 to 10 VDC.
5. The Reset Setpoint can be above or below the Supply Air Temperature Setpoint.

### Cutoff Mode

---

1. If the Supply temperature rises above 200°F, the MODGAS-X Controller will enter the Cutoff Mode.
2. In this mode, the MODGAS-X Controller will completely shut off.
3. This mode has higher priority than any other mode of operation and needs to be cleared before the unit can enter another mode.
4. The Cutoff Mode will be cleared if the Supply Air temperature drops below 190°F.
5. The Cutoff Mode will last at least 5 minutes.





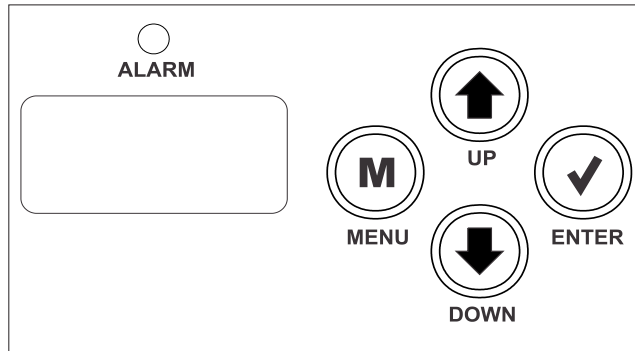

### LCD Display Screen & Navigation Keys

The MODGAS-X Controller allows you to make configuration changes, view status, change setpoints, create force modes, and perform diagnostics using the keypad next to the LCD display. See **Figure 10** and refer to **Table 3** for descriptions.



**Figure 10: LCD Display and Navigation Keys**

NAVIGATION KEY	KEY FUNCTION
<b>MENU</b> 	Use the MENU key to navigate through the Main Menu Screens.
<b>UP</b> 	Use this key to adjust setpoints and change configurations. This key is also used to turn Valve Force Mode on.
<b>DOWN</b> 	Use this key to adjust setpoints and change configurations. This key is also used to turn Valve Force Mode off.
<b>ENTER</b> 	Use the Enter key to move through screens within Main Menu categories. Also, use this key to save setpoints and configuration changes.

**Table 3: Navigation Key Functions**

# LCD DISPLAY SCREENS

## Main Screens Map and MODGAS Screens

### Main Screens Map

Refer to the following map when navigating through the LCD Main Screens. The first screen is an initialization screen. To scroll through the rest of the screens, press the **<MENU>** button.

MODGAS - X  
1044 V. XXX

Press  to scroll through MODGAS Screens.

Press  to go to STATUS Screens.

STATUS

Press  to scroll through STATUS Screens.

Press  to go to ALARMS Screens.

ALARMS

Alarms will display automatically.

Press  to go to SETPOINTS Screens.

SETPOINT

Press  to scroll through SETPOINTS Screens.

Press  to go to FORCE Screens.

FORCE  
VALVES

Press  to scroll through FORCE Screens.

### Main MODGAS Screens

From the MODGAS Screen, press **<ENTER>** to scroll through the screens.

MODGAS - X  
1044 V. XXX



S/A MODE,  
S/A MODE LOCKED  
or COMM MODE

In Stand-Alone Mode, the screen will display S/A MODE or S/A MODE LOCKED. In Communications Mode, the screen will display COMM MODE and the items below will scroll through the screen:

1. Number of good packets being received. This will roll over after 9999. Example: +XXXX.
2. Number of checksum errors. This will stop at 9999. Example: C-XXXX
3. Number of packet length errors. This will stop at 9999 until power is cycled. Example: P-XXXX.
4. Number of initialization errors if communication is I<sup>2</sup>C. Example: I-XXXX.



SOFTWARE  
1044 V. XXX

#### CURRENT SOFTWARE VERSION



ADDRESS  
1 (138)

#### CURRENT BOARD ADDRESS

Number in parentheses is E-BUS address.



VALV CONFG  
0-20 VLT OR  
0-10 VLT

#### VALVE CONFIGURATION

0-20 Volt (Standard MODGAS-X Controller)  
0-10 Volt (10 to 1 Ratio Controller)



# STAGES  
T=2 M=2

#### NUMBER OF STAGES CONFIGURED

T = Total stages fixed and modulating M = Total modulating stages

### Status Screens

Refer to the following map when navigating through the Status Screens. From the STATUS Screen, press **<ENTER>** to scroll through the screens.



Status Screens shown below will scroll automatically if LCD display is left on this screen for 20 seconds.

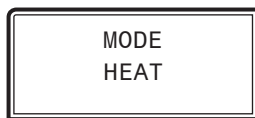

#### MODE

This screen displays the current mode of operation of the MODGAS-X Controller. The mode options are:

**OFF:** This mode will display when there is no call for heat and heating has been disabled.

**HIGH FIRE:** Each time Heat is activated, the unit will first go into High Fire Mode. During this mode, the unit will remain at maximum fire. The unit will leave this mode once proof of fire has been established.

**HEAT:** After High Fire, the unit will enter the Heat Mode and will begin to modulate the gas valve to maintain the Heating Supply Air Setpoint (SAT). The unit must remain in this mode for a minimum run time of 1 minute. While in Heat Mode, the screen will display the staging status—HEAT STAGE 1 to STAGE 16. If Modulating Staged Heat, the screen will display MOD HEAT. Once the call for heat goes away, the unit will leave the Heat Mode.

**CUTOFF:** The Cutoff Mode occurs if the SAT rises above 200°F. During Cutoff Mode, the Heat will be disabled for a fixed delay period. If the SAT falls below 200°F and the delay period has expired, the unit will re-enter the Heat Mode.

**FORCE:** Force Mode.

**SAT FAIL:** The Supply Air Temperature sensor has been disconnected for more than 60 seconds. This alarm will be disabled when the sensor is reconnected.

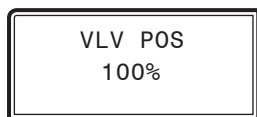

#### VALVE POSITION

0 to 100 percent



#### SUPPLY AIR TEMPERATURE

40°F to 200°F or 5°C to 93°C.

If no sensor is detected, screen will display "NO SENSR"

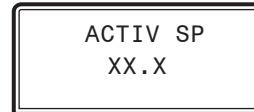

#### ACTIVE SUPPLY AIR SETPOINT

Calculated from SAT setpoint and reset signal in stand-alone mode. In communicating mode, the Main Controller sends the setpoint.



#### FAN SPEED

OFF, HIGH, LOW

### Alarm Screens

Refer to the following map when viewing Alarm Screens. These screens will display automatically when alarms are present. For alarm troubleshooting, see **pages 23 & 24**.



#### ALARMS

The alarms are as follows:

**NO ALARMS:** This will be shown if there are no current alarms.

**SAT CUTOFF:** This indicates a Supply Air Temperature Cutoff Alarm condition which is activated if the SAT has risen above 200°F. The alarm will go away if after a fixed delay period the SAT has dropped below 200°F.

**MECH FAILURE:** The unit has been in High Fire Mode for more time than the mechanical failure delay period. This alarm will be disabled when the unit leaves High Fire Mode. **NOTE:** This alarm was removed in version 3.06.

**SAT FAIL ERROR:** The Supply Air Temperature sensor has been disconnected for more than 60 seconds. This alarm will be disabled when the sensor is reconnected.

**COMM T/O ERROR:** Communications have been lost with the main controller. This alarm will disable when communications resume.

# LCD DISPLAY SCREENS

## Setpoint & Force Screens

### Setpoint Screens

Refer to the following map when navigating through the Setpoint Screens. From the SETPOINTS Screen, press **<ENTER>** to scroll through the screens and change setpoints. Use the **<UP>** and **<DOWN>** arrow keys to change your selections. Then press **<ENTER>** to save the new setpoint.

**NOTE:** When the MODGAS-X is operating in Communications Mode, these setpoint screens will not appear on the LCD display because they are controlled by the Main Controller.

SETPOINTS



SAT SP  
40 - 200 °F  
5 - 93 °C

#### HEATING SUPPLY AIR TEMPERATURE SETPOINT

This is the target temperature while the heating is enabled. If you are using the reset signal, this is the setpoint it will calculate to at zero volts. Will display only in stand-alone mode.

The SAT Setpoint is set by the LCD Display in stand-alone mode and is set by the Main Controller in communicating mode.

Minimum	Default	Maximum
40°F	120°F	200°F
5°C	49°C	93°C



RESET SP  
40 - 200 °F  
5 - 93 °C

#### RESET HEATING SUPPLY AIR SETPOINT

This is the maximum temperature at which the Supply Air Temperature will reset to. Will display only in stand-alone mode.

The Reset Setpoint is set by the LCD Display in stand-alone mode and is set by the Main Controller in communicating mode.

Minimum	Default	Maximum
40°F	120°F	200°F
5°C	49°C	93°C



### Force Screens

Refer to the following map when navigating through the Force Screens. From the FORCE Screen, press **<ENTER>**.

FORCE  
VALVES



FORCE  
MODE ON/OFF

Press the **<UP>** button to turn the Force Mode on.  
Press the **<DOWN>** button to turn the Force Mode off.



FRC VALV  
X%

#### FORCE VALVE PERCENTAGE

This screen only appears when Force Mode is on.

Press the **<UP>** button to increase the percentage.  
Press the **<DOWN>** button to decrease the percentage.

**NOTE:** When you turn the Force Mode back off or after 1 hour has elapsed, the valve will reinitialize to zero.



The next 15 screens are for Relays Only.

STAGE 1  
MODULATING

This Relay cannot be forced.

STAGE 2 - 14  
FORCE ON OR OFF

Press the **<UP>** button to turn the Force Relay on.  
Press the **<DOWN>** button to turn the Force Relay off.

FORCE  
TIMEOUT

#### FORCE MODE TIME OUT

This screen will appear when the Force Mode times out after 1 hour.

## Protected Screens Map and Diagnostic Screens

### Protected Screens Map

From the MODGAS Screen, press **<ENTER>** twice until you get to the SOFTWARE Screen. Then hold the **<UP>** button for 5 seconds. To scroll through the rest of the screens, press the **<MENU>** button.

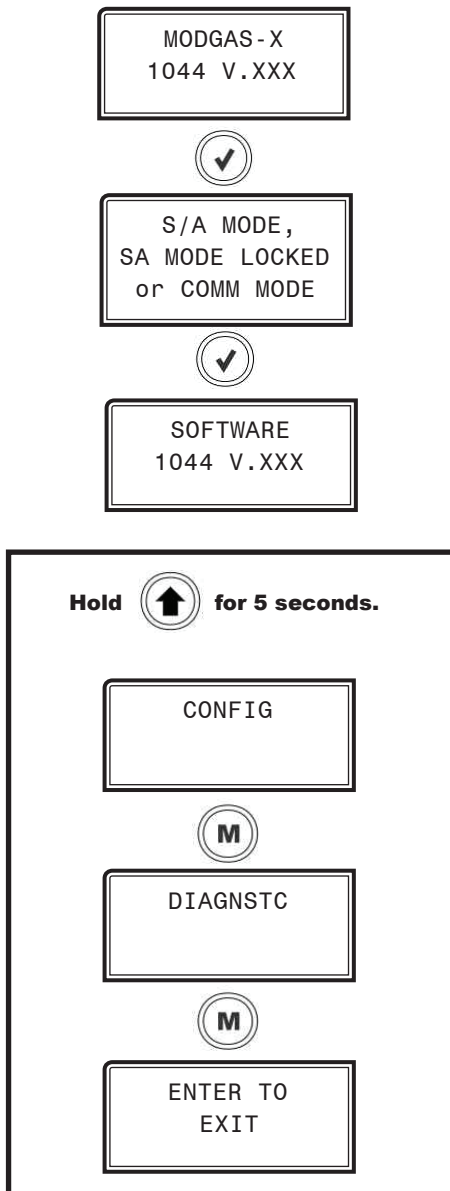

### Diagnostic Screens

Refer to the following map when navigating through the Diagnostic Screens. From the DIAGNSTC Screen, press **<ENTER>** to scroll through the screens.

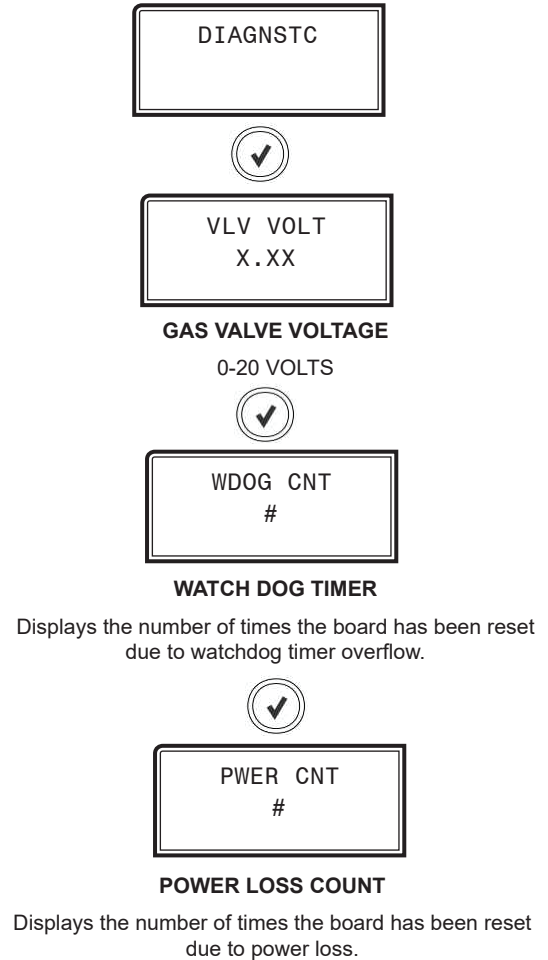

## Configuration Screens

### Configuration Screens

Refer to the following map when navigating through the Configuration Screens. From the CONFIG Screen, press **<ENTER>** to scroll through the screens and change setpoints. Use the **<UP>** and **<DOWN>** arrow keys to change your selections. Press **<ENTER>** to save any changes.

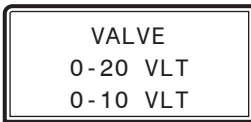

#### VALVE TYPE

**0-20 (Default):** Regular Analog Maxitrol Valve  
**0-10:** Maxitrol Stepper Valve

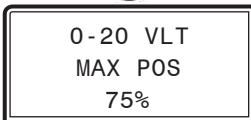

#### 0-20 VLT VALVE ADJUSTMENT

**75% = 5 Volts Output**  
**100% = 0 Volts Output**

This screen lets you adjust maximum Valve position during Heat mode.

The valve needs to be adjusted according to gas pressure to be as close to 75% as possible.

Adjusting too high may affect performance of the PID routine to maintain Supply Air Setpoint at lower demand situations.

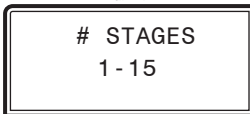

#### If Staging w/Fixed was selected—# OF STAGES

Select number of stages. 1-15. You must press the ENTER key in order to save the configuration, so that when any power cycles, the unit will run with the saved settings.



#### CURRENT ADDRESS OF THE BOARD

The address is only used in communicating mode. Default = 1

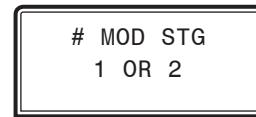

#### NUMBER OF MODULATING STAGES

0-20 Volt - Range is 1 or 2. Default is 1.  
0-10 Volt - Range is 1 or 8. Default is 1.

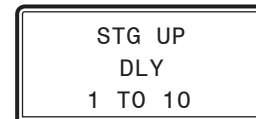

#### STAGE UP DELAY

Range is 1 to 10 minutes. Default is 3.

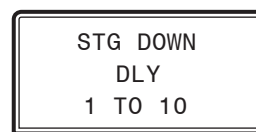

#### STAGE DOWN DELAY

Range is 1 or 10 minutes. Default is 1.

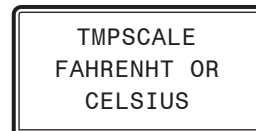

#### TEMPERATURE SCALE

Fahrenheit (default) or Celsius.  
This setting is used only in stand-alone mode.

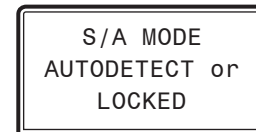

#### S/A MODE FORCED

S/A Mode Autodetect (default) or Locked.  
Forces the module to be Stand-Alone only.

If there is a 12 Relay Board with additional Heat Stages on a stand-alone unit, this must be set to locked.

### LED Diagnostics

The MODGAS-X Controller is equipped with LEDs that can be used to verify operation and perform troubleshooting. There are LEDs for communication, operation modes, and diagnostic codes. The module has 10 LEDs—8 used for operation & status, and 2 used for alarms.

See **Figure 11, page 24** for the LED locations. The LEDs associated with these inputs and outputs allow you to see what is active without using a voltmeter. The LEDs and their uses are as follows:

#### Operation LEDs

**POWER** - This green LED will light up to indicate that 24 VAC power has been applied to the controller.

**STATUS** - This green LED will light up and blink the board address at startup. It will then blink every 10 seconds according to what mode the controller is in. See **Table 4**.

No. of Blinks	STATUS LED
1	Off Mode
2	High Fire Mode
3	Heating Mode
4	Force Mode

**Table 4: STATUS LED Blink Codes**

#### Diagnostic LEDs

**ALARM** - This red LED located on the MODGAS-X Controller's cover above the LCD display will light up to indicate an alarm. The type of alarm(s) will be shown on the LCD display. The ALARM LED also blinks when the expansion valve is initializing at startup.

The ALARM LED on the MODGAS-X board will blink an alarm code when an alarm(s) occurs. The highest priority failure code will be indicated first. You must correct the highest priority alarm before other problems will be indicated. See **Table 5**.

No. of Blinks	ALARM LED
1	Mechanical Failure
2	Supply Air Temperature Sensor Failure
3	SAT Cutoff Mode
4	Communications Time Out Error

**Table 5: ALARM LED Blink Codes**

#### Communication LED

**COMM** - This yellow LED will light up and blink when communications are detected.

#### Relay LEDs

**RLY1** - This green LED will light up and stay lit as long as the Fan relay is active.

**RLY2** - This green LED will light up and stay lit as long as the Low Speed Fan relay is active.

**RLY3** - This green LED will light up and stay lit as long as the Auxiliary Heat 1 relay is active.

**RLY4** - This green LED will light up and stay lit as long as the Auxiliary Heat 2 relay is active.

#### Binary Input LEDs

**AUX BIN** - Not Used.

**HEAT EN** - This green LED will light up when Heat is enabled.

### Troubleshooting Alarms

#### Mechanical Failure:

**NOTE:** This alarm was removed in version 3.06.

- Check relay outputs on the MODGAS-X for 24 VAC output.
- Verify the SAT OPTIONS jumper settings on the MODGAS-X for Supply Air Temperature Sensor.
- Verify output voltage (VOUT and GND) to gas valve. Try forcing valves (refer to Force Screens in this guide).
- Verify that the Supply Air Temperature Sensor is connected to SAT and GND on the MODGAS-X (stand-alone mode and when using VAV/CAV or MUA Controller) or to AI2 & GND or AI3 & GND on the Main Controller (communicating mode).
- Verify Supply Air Temperature Sensor probe is mounted correctly in supply duct.
- Remove SAT and GND wiring from the MODGAS-X and ohm the sensor out (this may indicate open or failed wiring). Refer to chart in back of this guide for readings.

# TROUBLESHOOTING

## Alarms & LED Locations

### Supply Air Temperature Failure:

- Verify that the Supply Air Temperature Sensor is connected to the SAT and GND on the MODGAS-X (stand-alone mode or when using Retrofit Applications) or to AI2 & GND or AI3 & GND on specific Main Controllers (communicating mode). See **Table 8, page 28**.
- Remove SAT and GND wiring from MODGAS-X and ohm the sensor out (this may indicate open or failed wiring). Refer to chart in back of this guide for readings.
- Verify the SAT OPTIONS jumper settings on the MODGAS-X for the Supply Air Temperature Sensor.

### Sat Cutoff Mode:

- Remove SAT and GND wiring from the MODGAS-X and ohm the sensor out (this may indicate open or failed wiring). Refer to chart in back of guide for readings.

- With Supply Air Sensor disconnected from the MODGAS-X, set volt meter to DC volts and measure voltage between SAT and GND on board. Refer to **Tables 6 & 7, pages 25 & 26** for readings.
- Verify Supply Air Temperature Sensor reading in duct with 3rd party temperature testing device.

### Communications Loss:

- Check COMM LED on MODGAS-X.
- Verify 24 VAC power to all interconnected AAON controllers.
- Verify connection between the MODGAS-X and associated AAON controllers.
- In communication mode (connected to an AAON Unit with modular cable), confirm that Unit Controller's MODGAS-X status screen displays MODGAS-X's Supply Air Temperature and that Main MODGAS screens show COMM MODE.

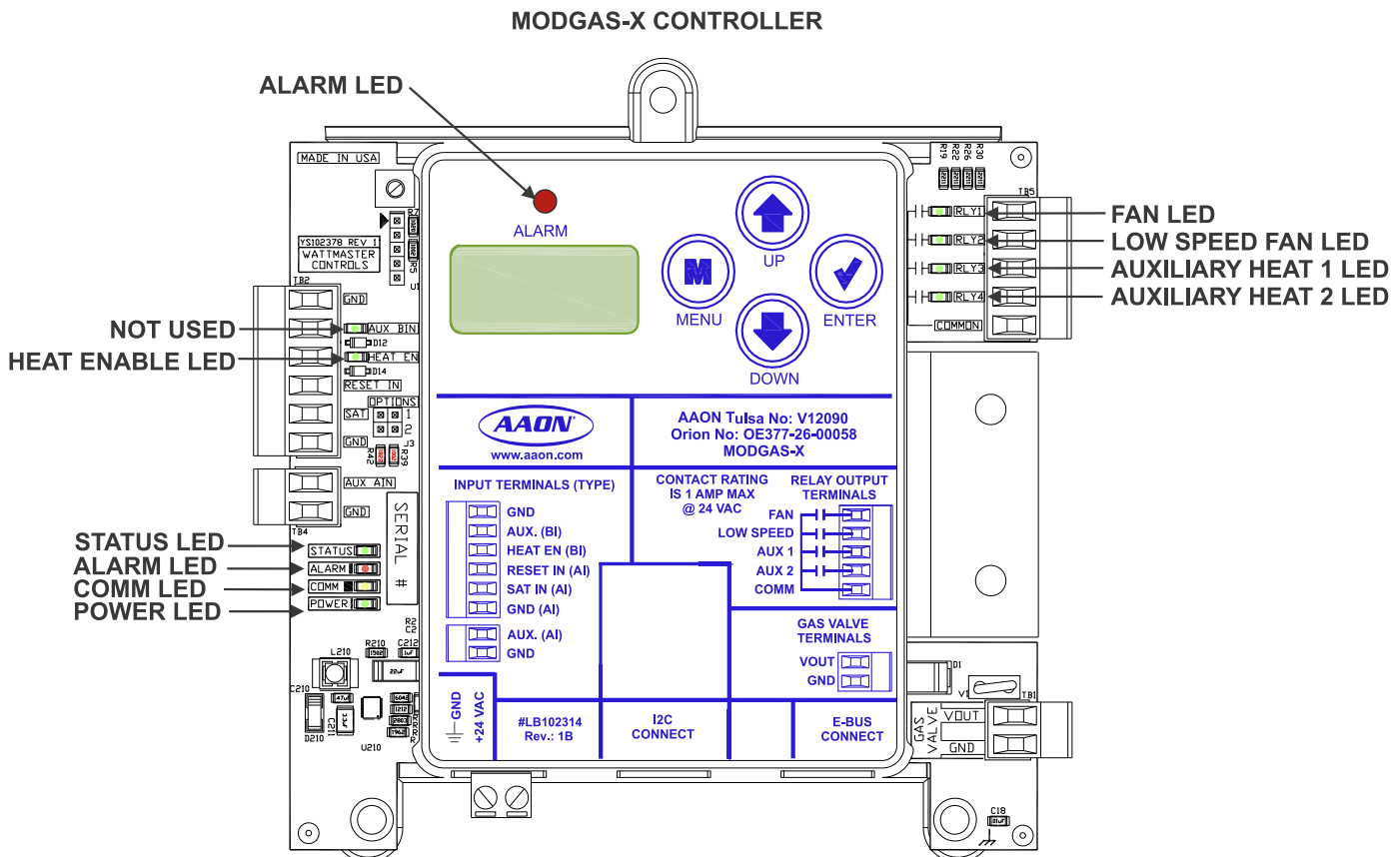

Figure 11: MODGAS-X Controller LED Locations and Descriptions



**Other Checks**

**0-3V (SAT OPTIONS Jumper Setting 1) & 0-5V (SAT OPTIONS Jumper Setting 2) Supply Air Temperature Sensor**

If you suspect the Supply Air Temperature Sensor is not reading correctly, make sure the wiring terminal connections are tight and that any wiring splices are properly connected. You can check the operation of the Supply Air Temperature Sensor by measuring the resistance or voltage using a digital multimeter. Set the meter to DC Volts. Place the positive probe on the AIN terminal and the negative probe on the GND terminal. Read the DC Volts and find that voltage in Tables 6 & 7, below & on page 26.

Read the temperature corresponding with that voltage and determine if this is close to the actual temperature the sensor is exposed to. If the temperature from the chart is different by more than a few degrees, you probably have a defective or damaged sensor. You can also check the sensor resistance to determine correct operation. To read the resistance, set the meter to Ohms. Unplug the sensor connector from the board and measure the resistance across the disconnected wires. This resistance should match the corresponding temperature from Tables 6 & 7, below & on page 26.

Temperature to Resistance/Voltage Chart			
Temp (°F)	Temp (°C)	Resistance (Ohms)	Voltage @ Input (VDC)
-10	-23.3	93333	2.98
-5	-20.6	80531	2.94
0	-17.8	69822	2.89
5	-15.0	60552	2.83
10	-12.2	52500	2.77
15	-9.4	45902	2.71
20	-6.7	40147	2.64
25	-3.9	35165	2.57
30	-1.1	30805	2.49
35	1.6	27140	2.41
40	4.4	23874	2.33
45	7.2	21094	2.24
50	10.0	18655	2.15
52	11.1	17799	2.11
54	12.2	16956	2.08
56	13.3	16164	2.04
58	14.4	15385	2.00
60	15.6	14681	1.96

**Table 6: 0-3V Temperature Sensor - Voltage & Resistance for Type III Sensors**

Temperature to Resistance/Voltage Chart			
Temp (°F)	Temp (°C)	Resistance (Ohms)	Voltage @ Input (VDC)
62	16.7	14014	1.93
64	17.8	13382	1.89
66	18.9	12758	1.85
68	20.0	12191	1.81
69	20.6	11906	1.79
70	21.1	11652	1.78
71	21.7	11379	1.76
72	22.2	11136	1.74
73	22.7	10878	1.72
74	23.3	10625	1.70
75	23.9	10398	1.68
76	24.4	10158	1.66
78	25.6	9711	1.63
80	27.8	9302	1.59
82	27.8	8893	1.55
84	28.9	8514	1.52
86	30.0	8153	1.48
88	31.1	7805	1.45
90	32.2	7472	1.41
95	35.0	6716	1.33
100	37.8	6047	1.24
105	40.6	5453	1.16
110	43.3	4923	1.09
115	46.1	4449	1.02
120	48.9	4030	.95
125	51.7	3656	.88
130	54.4	3317	.82

**Table 6, continued: 0-3V Temperature Sensor - Voltage & Resistance for Type III Sensors**

**Thermistor Sensor Testing Instructions**

- 1.) Use the resistance column to check the thermistor sensor while disconnected from the controllers (not powered).
- 2.) Use the voltage column to check sensors while connected to powered controllers. Read voltage with meter set on DC volts. Place the “-” (minus) lead on GND terminal and the “+” (plus) lead on the sensor input terminal being investigated.

*If the voltage is above 3.3 VDC, the sensor or wiring is “open.” If the voltage is less than 0.05 VDC, the sensor or wiring is shorted.*

## SAT Sensor Testing

Temperature to Resistance/Voltage Chart			
Temp (°F)	Temp (°C)	Resistance (Ohms)	Voltage @ Input (VDC)
-10	-23.3	93333	4.620
-5	-20.6	80531	4.550
0	-17.8	69822	4.474
5	-15.0	60552	4.390
10	-12.2	52500	4.297
15	-9.4	45902	4.200
20	-6.7	40147	4.095
25	-3.9	35165	3.982
30	-1.1	30805	3.862
35	1.6	27140	3.737
40	4.4	23874	3.605
45	7.2	21094	3.470
50	10.0	18655	3.330
52	11.1	17799	3.275
54	12.2	16956	3.217
56	13.3	16164	3.160
58	14.4	15385	3.100
60	15.6	14681	3.042
62	16.7	14014	2.985
64	17.8	13382	2.927
66	18.9	12758	2.867
68	20.0	12191	2.810
69	20.6	11906	2.780
70	21.1	11652	2.752
71	21.7	11379	2.722
72	22.2	11136	2.695
73	22.7	10878	2.665
74	23.3	10625	2.635
75	23.9	10398	2.607
76	24.4	10158	2.577
78	25.6	9711	2.520
80	27.8	9302	2.465
82	27.8	8893	2.407
84	28.9	8514	2.352
86	30.0	8153	2.297
88	31.1	7805	2.242
90	32.2	7472	2.187
95	35.0	6716	2.055

**Table 7: 0-5V Temperature Sensor - Voltage & Resistance for Type III Sensors**

Temperature to Resistance/Voltage Chart			
Temp (°F)	Temp (°C)	Resistance (Ohms)	Voltage @ Input (VDC)
100	37.8	6047	1.927
105	40.6	5453	1.805
110	43.3	4923	1.687
115	46.1	4449	1.575
120	48.9	4030	1.469
125	51.7	3656	1.369
130	54.4	3317	1.274
135	57.2	3015	1.185
140	60.0	2743	1.101
145	62.8	2502	1.024
150	65.6	2288	0.952

**Table 7, cont.: 0-5V Temperature Sensor - Voltage & Resistance for Type III Sensors**

### Thermistor Sensor Testing Instructions

- 1.) Use the resistance column to check the thermistor sensor while disconnected from the controllers (not powered).
- 2.) Use the voltage column to check sensors while connected to powered controllers. Read voltage with meter set on DC volts. Place the “-” (minus) lead on GND terminal and the “+” (plus) lead on the sensor input terminal being investigated.

*If the voltage is above 5.08 VDC, the sensor or wiring is “open.” If the voltage is less than 0.05 VDC, the sensor or wiring is shorted.*

**Supply Air Temperature Sensor Installation**

**Mounting the Supply Air Temperature Sensor**

- The Supply Air Temperature (SAT) Sensor should be located in the duct-work downstream of the unit supply air connection.
- Locate the sensor in the center of the widest part of the duct. Use the supplied template and a 5/16" drill to make a hole for the sensor.
- Install the gasket over the probe and mount securely to the duct using the supplied sheet metal screws. Be sure the gasket is compressed to provide an air tight seal.
- For best accuracy, apply insulation on the outside of the duct, over the sensor. This will help prevent thermal gradients from affecting the sensor.

**WARNING:** Make sure your Supply Air Temperature Sensor is mounted and wired according to these instructions prior to testing the unit or else the modulating valve will not control properly and may damage your equipment.

**Stand-Alone Mode**

In Stand-Alone Mode, the SAT Sensor is connected to the MODGAS-X Controller. If, in Stand-Alone Mode, the MODGAS-X Controller is used in conjunction with a Stand-Alone MHGRV Controller, the SAT sensor is shared between the two controllers and always attaches to the MODGAS-X Controller.

See **Table 9, page 28** for SAT Options Jumper Settings and see **Figures 2, 4, and 5 - 8** for wiring. See **Table 8, page 28** for details about retrofit applications.

**Communication Mode**

When communicating with AAON Unit Controllers, the SAT Sensor will be connected to the Main Controller. The exception would be in retrofit applications with older controllers. See **Table 10, page 28** for SAT Options Jumper Settings and see **Figures 3 & 9** for wiring. See **Table 8, page 28** for details about retrofit applications.

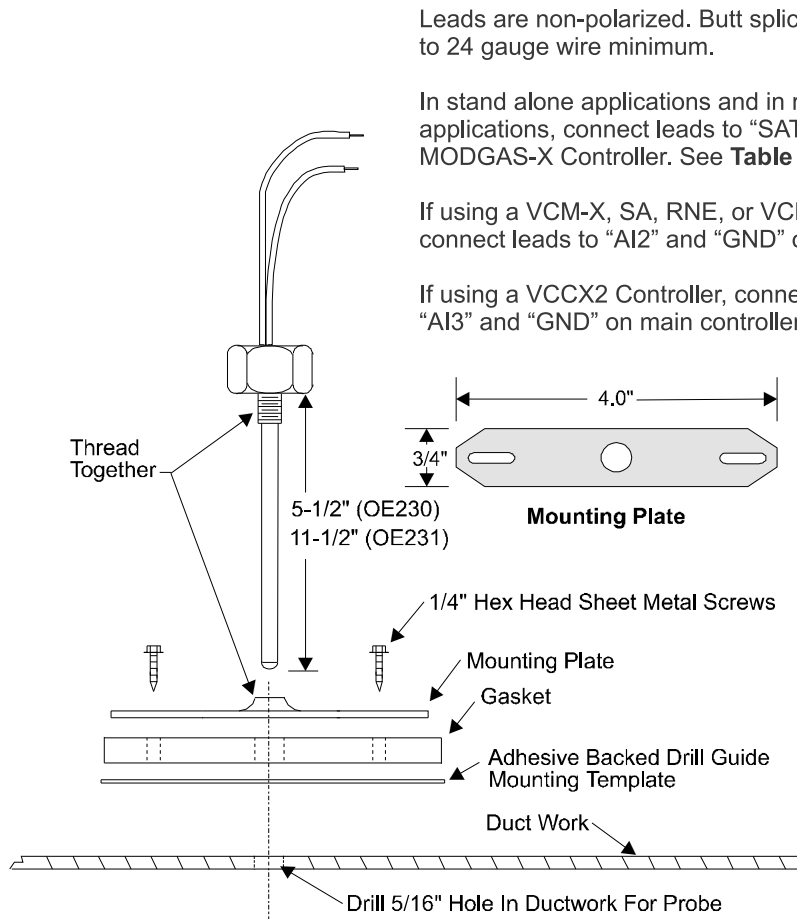

Leads are non-polarized. Butt splice leads to 24 gauge wire minimum.

In stand alone applications and in retrofit applications, connect leads to "SAT" and "GND" on MODGAS-X Controller. See **Table 8, Page 28**.

If using a VCM-X, SA, RNE, or VCB-X Controller, connect leads to "AI2" and "GND" on main controller.

If using a VCCX2 Controller, connect leads to "AI3" and "GND" on main controller.

**Figure 12: Supply Air Temperature Sensor Installation**

# APPENDIX A

## SAT Sensor Wiring Guide & Jumper Settings

### SAT Wiring Conditions

	MODGAS-X ONLY	MHGRV-X ONLY	MODGAS-X & MHGRV-X
STAND-ALONE	Install Supply Air Sensor in MODGAS-X.	Install Supply Air Sensor in MHGRV-X. Set "SAT Options" Jumpers to "Normal".	Install Sensor in MODGAS-X and daisy-chain it to the MHGRV-X. Set "SAT Options" Jumpers to "MODGAS X". If connected to a MODGAS II Retrofit, Set "SAT Options" Jumpers to "MODGAS".
VCCX2, VCB-X	Install Supply Air Sensor in VCCX2 or VCB-X. Connect to VCCX2 or VCB-X using E-BUS cable.	Install Supply Air Sensor in VCCX2 or VCB-X. Connect to VCCX2 or VCB-X using E-BUS cable.	Install Supply Air Sensor in VCCX2 or VCB-X. Connect to VCCX2 or VCB-X using E-BUS cable.
VCM-X, SA, RNE	Install Supply Air Sensor in Main Controller. Connect to Main Controller using I <sup>2</sup> C cable.	Install Supply Air Sensor in Main Controller. Connect to Main Controller using I <sup>2</sup> C cable.	Install Supply Air Sensor in Main Controller. Connect to Main Controller using I <sup>2</sup> C cable.
VCM, VAV/CAV, MUA, MUA II, MUA IID	Install Supply Air Sensor in MODGAS-X. Connect to Main Controller using I <sup>2</sup> C cable.	Install Supply Air Sensor in MHGRV-X. Connect to Main Controller using I <sup>2</sup> C cable.	Install Supply Air Sensor in MODGAS-X. Connect to Main Controller using I <sup>2</sup> C cable.

**Table 8: SAT Wiring Conditions**

### SAT Options Jumper Settings

Refer to **Tables 9 & 10** to determine the settings. See **Figure 2, page 5** for jumper locations.

STAND-ALONE MODE SAT OPTIONS JUMPER SETTINGS*	
CONDITION	JUMPER SETTING
MODGAS-X Only	1
MODGAS-X with MHGRV-X**	1
MODGAS-X with MHGRV II***	2
MODGAS-X with MHGRV III	2
* For SAT Sensor testing, use <b>Table 6, page 25</b> for jumper setting 1 and <b>Table 7, page 26</b> for jumper setting 2.	
** In this situation, also set MHGRV-X SAT Option to MODGAS-X. See the <i>MHGRV-X Technical Guide</i> for more information.	
*** The MHGRV II must have PU resistor installed.	

**Table 9: Stand-Alone Mode SAT OPTIONS Jumper Settings**

COMMUNICATIONS MODE SAT OPTIONS JUMPER SETTINGS*	
CONDITION	JUMPER SETTING
VCM-X / RNE / SA*	1
VCM, MUA, MUA II, MUA IID VAV/CAV**	1
VCCX2, VCB-X*	1
* For SAT Sensor testing, use <b>Table 6, page 25</b> for jumper setting 1. SAT should be connected to the Main Controller.	
** For SAT Sensor testing, use <b>Table 6, page 25</b> for jumper setting 1. SAT should be connected to the MODGAS-X Controller.	

**Table 10: Communications Mode SAT OPTIONS Jumper Settings**

**MODGAS-X Replacement of MODGAS II**

**Replacing the MODGAS II with the MODGAS-X**

The retrofit replacement involves a few easy steps. Refer to Figure 13, below.

**WARNING:** Do Not Connect Power To VOUT/Ground Terminal Block!

**STAND-ALONE MODE OPERATION**

- Step 1:** Disconnect power from the MODGAS II Controller.
- Step 2:** Disconnect the Supply Air Temperature Sensor from the MODGAS II and wire it to the MODGAS-X. If the Supply Air Temperature Sensor is being shared with a Stand-Alone MHGRV Controller, maintain the same wiring with the MHGRV Controller.

- Step 3:** Wire all other inputs and outputs per Figure 2, page 5.
- Step 4:** Set the SAT Options Jumper per Table 9, page 28.
- Step 5:** Connect power to the MODGAS-X Controller.

**COMMUNICATIONS MODE OPERATION**

- Step 1:** Disconnect power from the MODGAS-X Controller.
- Step 2:** The Supply Air Temperature Sensor needs to remain installed on whatever controller it is currently on. If it is currently installed on the MODGAS II Controller, then reinstall it on the MODGAS-X Controller.
- Step 3:** Set the SAT Options Jumper per Table 10, page 28.
- Step 4:** Connect power to the MODGAS-X Controller.

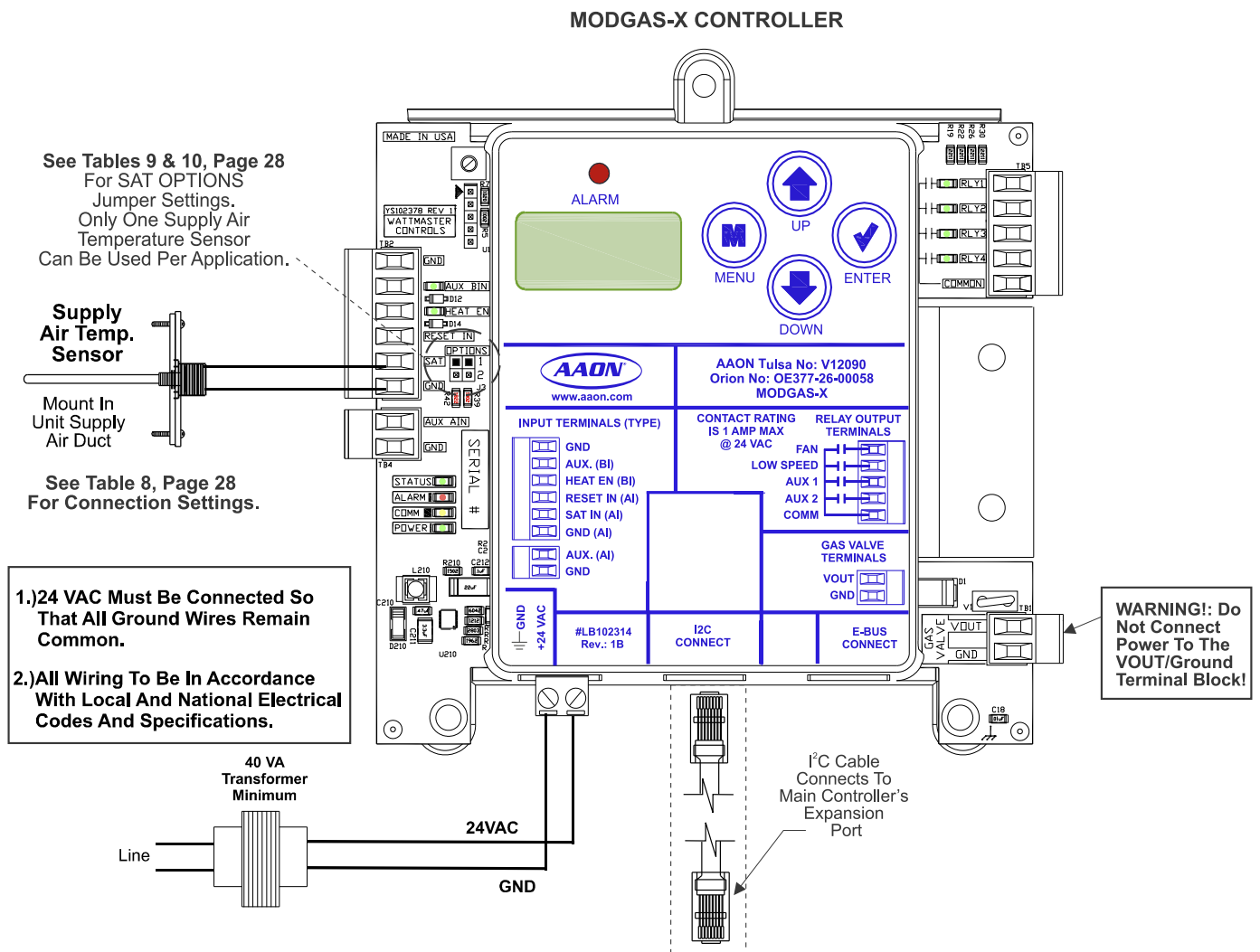

Figure 13: MODGAS-X Controller

**MAXITROL® Stepper Valve Types**



**Figure 14: 2-Wire 0-20 Volt Reverse Acting MAXITROL® Selectra Stepper Valve**



**Figure 15: 4-Wire 0-10 Volt Direct-Acting MAXITROL® EXA STAR Stepper Valve**





2425 South Yukon Ave • Tulsa, OK • 74107-2728

Ph: (918) 583-2266 • Fax: (918) 583-6094

**AAON® Part No.: V16940, Rev. 01H**

Printed in the USA • © October 2018 AAON • All Rights Reserved