

# RM7895A,B,C,D/EC7895A,C; RM7896A,B,C,D 7800 SERIES Relay Modules

## INSTALLATION INSTRUCTIONS

### APPLICATION

The RM7895A,B,C,D/EC7895A,C; RM7896A,B,C,D are microprocessor-based integrated burner controls for automatically fired gas, oil, or combination fuel single burner applications. They are intended to replace the R4795 and R7795 Primary Controls. The RM7895A,B,C,D/EC7895A; RM7896A,B,C,D systems consist of a relay module, subbase, amplifier, and purge card. Options include keyboard display module (KDM), Personal Computer Interface, Data ControlBus™ Module, remote display mounting, expanded annunciator and Combustion System Manager® Software.

Functions provided by the RM7895A,B,C,D/EC7895A,C; RM7896A,B,C,D include automatic burner sequencing, flame supervision, system status indication, system or self-diagnostics and troubleshooting. The RM7896 provides a postpurge function.

This document provides installation and static checkout instructions. Other applicable publications are:

Publication No.	Product
63-2278	Q7700 Network Interface Unit Product Data
65-0084	Q7800A,B 22-Terminal Wiring Subbase Product Data
65-0090	S7800A Keyboard Display Module Product Data
65-0091	S7810A Data ControlBus Module™ Product Data
65-0095	S7820 Remote Reset Module Product Data
65-0097	221729C Dust Cover Packing Instructions
65-0101	S7830 Expanded Annunciator Product Data
65-0102	ZM7850A Combustion System Manager™ Operating Instructions
65-0109	R7824, R7847, R7848, R7849, R7851, R7861, R7886 Flame Amplifiers for the 7800 Series Product Data

Publication No.	Product
65-0131	221818A Extension Cable Assembly Product Data
65-0229	7800 SERIES Relay Modules Checkout and Troubleshooting Product Data.
65-0092	QS7800A ControlBus™ Module, Standard
65-0227	QS7800B ControlBus™ Module, Multidrop

### SPECIFICATIONS

#### Electrical Ratings (See Table 3):

Voltage and Frequency:  
 RM7895/RM7896: 120 Vac (+10/-15%), 50/60 Hz (± 10%).  
 EC7895A,C: 220/240 Vac (+10%/-15%), 50/60 Hz (±10%)  
 Power Dissipation: 10W maximum.  
 Maximum Total Connected Load: 2000 VA.  
 Fusing Total Connected Load: 15A Fast Blow, type SC or equivalent.

#### Environmental Ratings:

Ambient Temperature:  
 Operating: -40°F to 140°F (-40°C to +60°C).  
 Storage: -40°F to 150°F (-40°C to +66°C).  
 Humidity: 85% relative humidity continuous, noncondensing.  
 Vibration: 0.5G environment.

#### Approvals:

RM7895/RM7896:  
 Underwriters Laboratories Inc. Listed: File No. MP268,  
 Guide No. MCCZ.  
 Canadian Standards Association Certified: LR9S329-3.  
 Factory Mutual Approved: Report No. J.I.1V9A0.AF.  
 IRI Acceptable.  
 Federal Communications Commission: Part 15, Class B,  
 Emissions.  
 EC7895A,C:  
 Factory Mutual Approved.



## INSTALLATION

### When Installing this Product...

1. Read these instructions carefully. Failure to follow them could damage the product or cause a hazardous condition.
2. Check the ratings given in the instructions and marked on the product to make sure the product is suitable for the application.
3. Installer must be a trained, experienced, flame safe-guard service technician.
4. After installation is complete, check out the product operation as provided in these instructions.

### WARNING

**Fire or Explosion Hazard.**

**Can cause property damage, severe injury, or death.**

Follow applicable safety requirements when installing a control on a burner to prevent death or severe injury.

### WARNING

**Electrical Shock Hazard.**

**Can cause serious injury, death or equipment damage.**

Disconnect power supply before beginning installation.

### IMPORTANT

1. *Wiring connections for the relay modules are unique; refer to Fig. 2 and 3 or the appropriate Specifications for proper subbase wiring.*
2. *Wiring must comply with all applicable codes, ordinances and regulations.*
3. *Wiring must comply with NEC Class 1 (Line Voltage) wiring.*
4. *Loads connected to the RM7895A,B,C,D/EC7895A,C; RM7896A,B,C,D must not exceed those listed on the RM7895A,B,C,D/EC7895A,C; RM7896A,B,C,D label or the Specifications; see Table 1.*
5. *Limits and interlocks must be rated to simultaneously carry and break current to the ignition transformer, pilot valve, and main fuel valve(s).*
6. *All external timers must be listed or component-recognized by authorities who have proper jurisdiction.*
7. *For on-off gas-fired systems, some authorities who have jurisdiction prohibit the wiring of any limit or operating contacts in series between the flame safeguard control and the main fuel valve(s).*
8. *Two flame detectors can be connected in parallel with the exception of Infrared Flame Detectors (C7015).*
9. *This equipment generates, uses and can radiate radio frequency energy and, if not installed and used in accordance with the instructions, can cause interference with radio communications. It has been tested and found to comply with the limits for a Class B computing device of Part 15 of FCC rules, which are designed to provide reasonable protection against such interference when operated in a commercial environment. Operation of this equipment in a residential area may cause interference, in which case, the users, at their own expense, may be required to take whatever measures are required to correct this interference.*
10. *This digital apparatus does not exceed the Class B limits for radio noise for digital apparatus set out in the Radio Interference Regulations of the Canadian Department of Communications.*

## Location

### Humidity

Install the relay module where the relative humidity never reaches the saturation point. The relay module is designed to operate in a maximum 85% relative humidity continuous, noncondensing, moisture environment. Condensing moisture can cause a safety shutdown.

### Vibration

Do not install the relay module where it can be subjected to vibration in excess of 0.5G continuous maximum vibration.

### Weather

The relay module is not designed to be weather tight. When installed outdoors, protect the relay module in an approved weather-tight enclosure.

## Mounting Wiring Subbase

1. Mount the subbase in any position except horizontally with the bifurcated contacts pointing down. The standard vertical position is recommended. Any other position decreases the maximum ambient temperature rating.
2. Select a location on a wall, burner or electrical panel. The Q7800 can be mounted directly in the control cabinet. Be sure to allow adequate clearance for service, installation, access or removal of the RM7895A,B,C,D/EC7895A,C; RM7896A,B,C,D, expanded annunciator, keyboard display module, flame amplifier, flame amplifier signal voltage probes, run/test switch, electrical signal voltage probes and electrical field connections.
3. For surface mounting, use the back of the subbase as a template to mark the four screw locations. Then drill the pilot holes.
4. Securely mount the subbase using four no. 6 screws (not provided).

## Wiring Subbase

### **⚠ WARNING**

**Electrical Shock Hazard.**  
**Can cause serious injury, death or equipment damage.**  
 Disconnect the power supply before beginning installation.

The internal block diagram of the RM7895A,B,C,D/EC7895A,C;RM7896A,B,C,D is shown in Fig. 1.

1. For proper subbase wiring and sequence chart, refer to Fig. 2 and 3.
2. For remote wiring of the Keyboard Display Module, refer to the Specifications for the Keyboard Display Module (65-0090), Network Interface Unit (63-2278), Data ControlBus™ Module (65-0091) or Extension Cable Assembly (65-0131).
3. Disconnect the power supply from the main disconnect before beginning installation to prevent electrical shock and equipment damage. More than one disconnect can be required.
4. All wiring must comply with all applicable electrical codes, ordinances and regulations. Wiring, where required, must comply with NEC, Class 1 (Line Voltage) wiring.
5. For recommended wire size and type, see Table 1.
6. For recommended grounding practices, see Table 2.

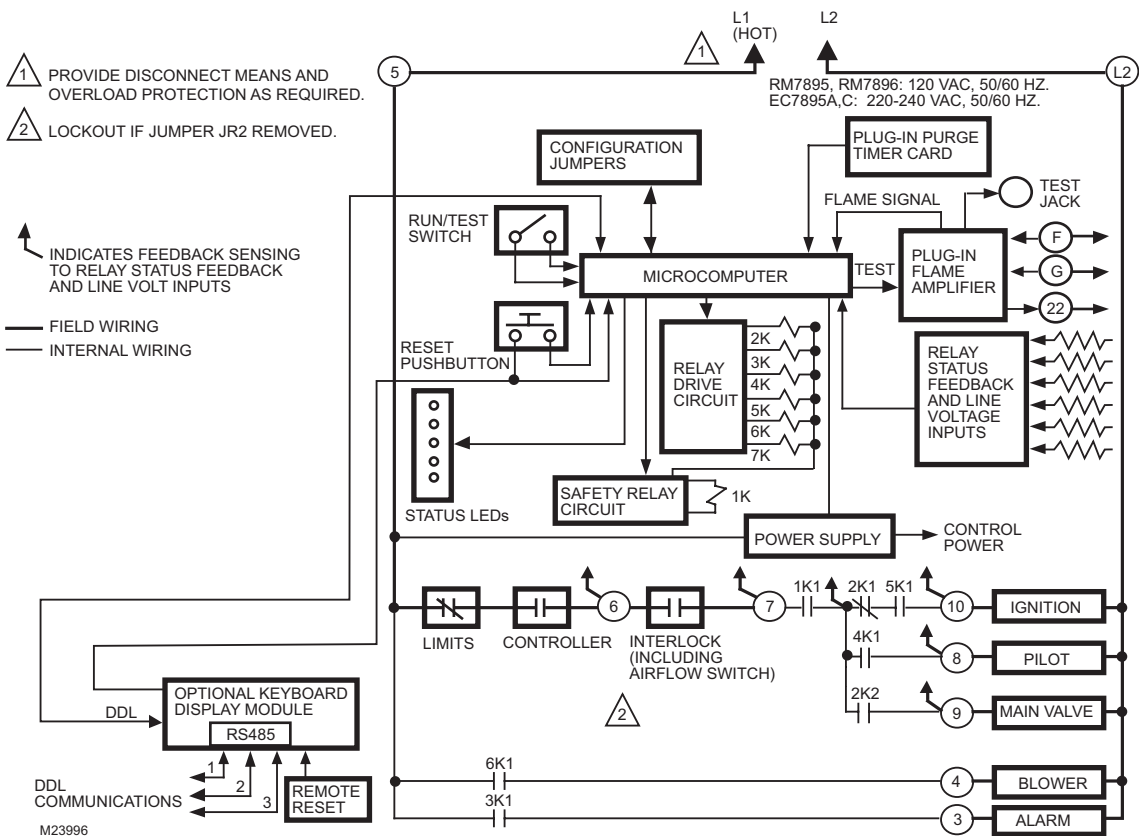

**Fig. 1. Internal block diagram of RM7895A,B,C,D/EC7895A,C; RM7896A,B,C,D (see Fig. 2 and 3 for detailed wiring instructions).**

RM7895A,B,C,D/EC7895A,C; RM7896A,B,C,D 7800 SERIES RELAY MODULES

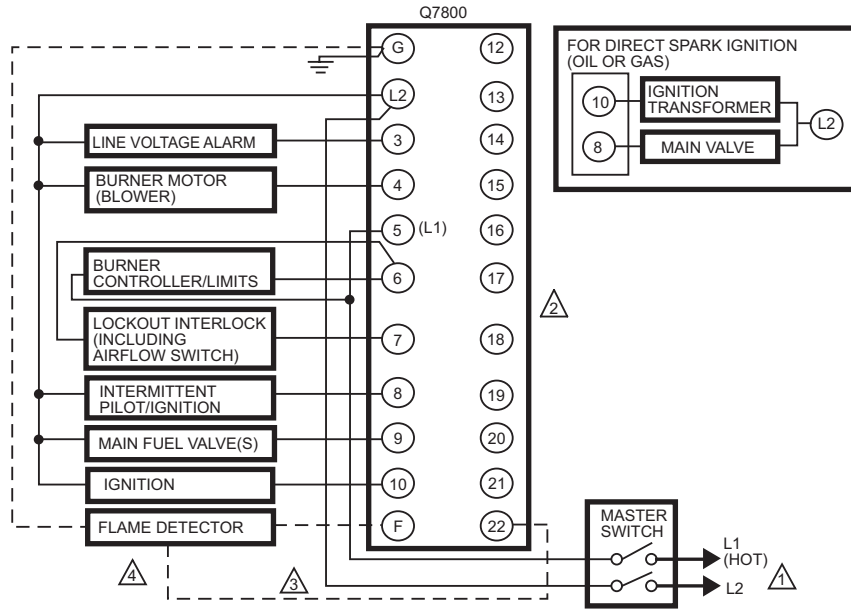

	00	00	00	00	PFEP 4 OR 10 SEC	00	00
	INITIATE	STANDBY	START	TIMED PURGE	4 OR 10 SEC	RUN	POST PURGE 15 SEC
LED DISPLAY	● POWER ○ ○ ○ ○	● POWER ○ ○ ○ ○	● POWER ○ ○ ○ ○	● POWER ○ PILOT ○ FLAME ○ MAIN ○ ALARM	● POWER ○ PILOT ● FLAME ○ MAIN ○ ALARM	● POWER ● PILOT ● FLAME ● MAIN ○ ALARM	● POWER ○ ○ ○ ○
BURNER START			BURNER/BLOWER MOTOR (4)				
				(10) IGN (5)			
					IGN/ PILOT (8)		
						MAIN VALVE (9)	
OPERATING CONTROLS AND INTERLOCKS			LIMITS AND BURNER CONTROLLER CLOSED (L1) TO (6)				
FLAME SIGNAL		AIRFLOW SW CHECK	LOCKOUT INTERLOCK CLOSED (6) TO (7)				AFSC
		SAFE START CHECK				FLAME PROVING	SSC

⚠️ RM7895, RM7896: 120 VAC, 50/60 HZ; EC7895: 220-240 VAC, 50/60 HZ POWER SUPPLY. PROVIDE DISCONNECT MEANS AND OVERLOAD PROTECTION AS REQUIRED.

⚠️ DO NOT CONNECT ANY WIRES TO UNUSED TERMINALS.

⚠️ FOR EC7895, A 220 TO 240 VAC TO 120 VAC, 10 VA MINIMUM STEPDOWN TRANSFORMER (NOT PROVIDED) MUST BE USED TO DRIVE THE SHUTTER.

⚠️ SEE FLAME DETECTOR SPECIFICATIONS FOR CORRECT WIRING.

⚠️ FOR RM7895A1048 (ONLY), IGNITION TERMINAL 10 IS DE-ENERGIZED WHEN FLAME IS PROVEN.

⚠️ AIRFLOW SWITCH CHECK FEATURE IS FOR THE RM7895B, RM7896B.

⚠️ RM7896A,B ONLY.

M23997

Fig. 2. Wiring subbase and sequence chart for RM7895A,B/EC7895A; RM7896A,B.

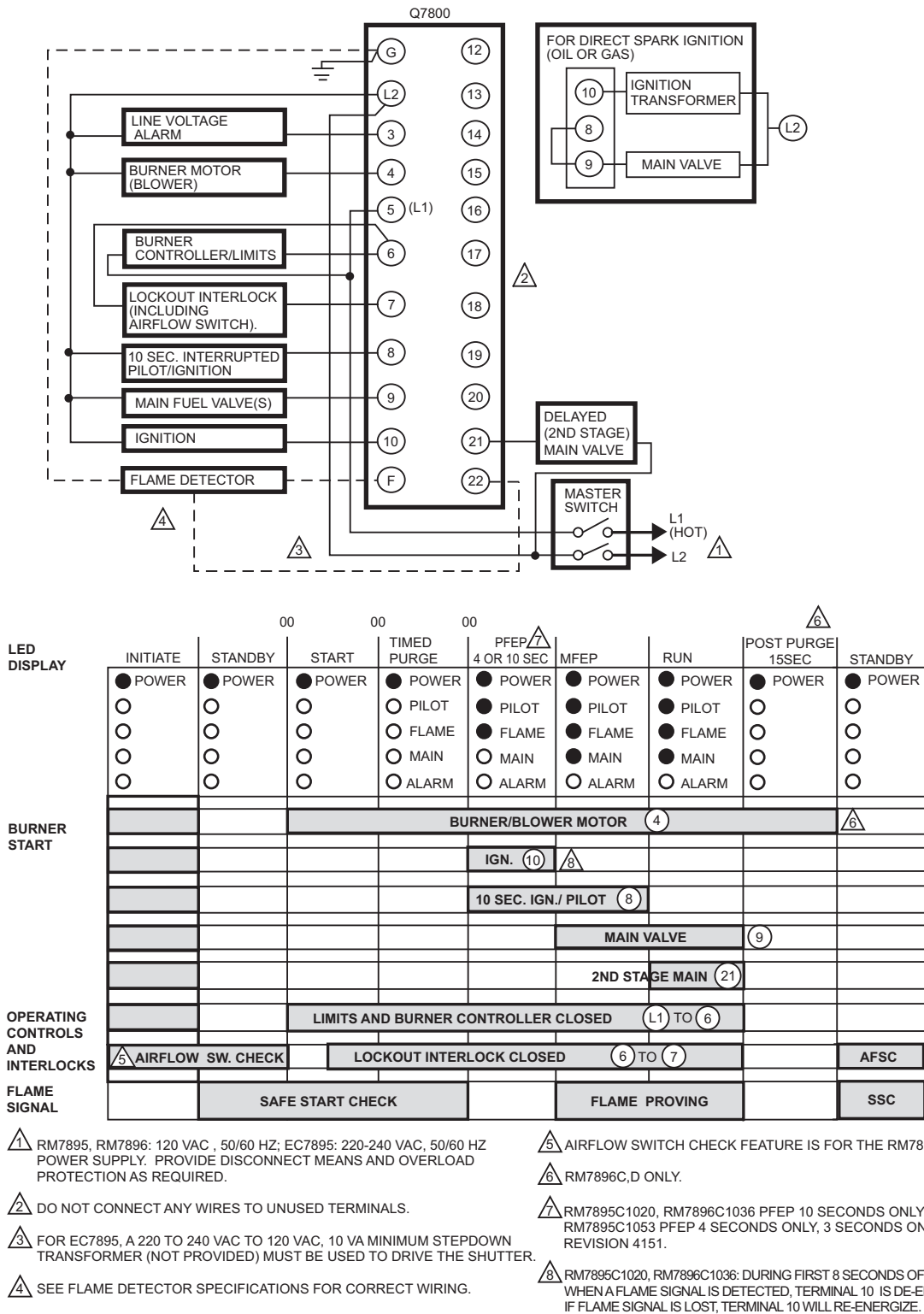

Fig. 3. Wiring subbase and sequence chart for RM7895C,D/EC7895C; RM7896C,D.

**Table 1. Recommended Wire Sizes and Part Numbers.**

Application	Recommended Wire Size	Recommended Part Numbers
Line voltage terminals.	14, 16 or 18 AWG copper conductor, 600 volt insulation, moisture-resistant wire.	TTW60C, THW75C, THHN90C.
Keyboard Display Module	22 AWG two-wire twisted pair with ground, or five-wire.	Belden 8723 shielded cable or equivalent.
Data ControlBus™ Module <sup>a</sup>	22 AWG two-wire twisted pair with ground, or five-wire.	Belden 8723 shielded cable or equivalent.
Remote Reset Module	22 AWG two-wire twisted pair, insulated for low voltage.	—
Communications Interface ControlBus™ Module <sup>a</sup>	22 AWG two-wire twisted pair with ground.	Belden 8723 shielded cable or equivalent.
13 Vdc full-wave rectified transformer power input.	18 AWG wire insulated for voltages and temperatures for given application.	TTW60C, THW75C, THHN90C.

<sup>a</sup> The KDM, Data ControlBus™ Module (for remote mounting or communications) or Communication Interface ControlBus™ Module must be wired in daisy chain configuration, 1(a)-1(a), 2(b)-2(b), 3(c)-3(c). The order of interconnection of all the devices listed above is not important. Be aware that modules on the closest and farthest end of the daisy chain configuration string require a 120 ohm (1/4 watt minimum) resistor termination across terminals 1 and 2 of the electrical connectors for connections over 100 feet (31 meters).

**Table 2. Recommended Grounding Practices.**

Ground Type	Recommended Practice
Earth ground (subbase and relay module).	<ol style="list-style-type: none"> <li>1. Use to provide a connection between the subbase and the control panel of the equipment. Earth ground must be capable of conducting enough current to blow the 20A fuse (or breaker) in the event of an internal short circuit.</li> <li>2. Use wide straps or brackets to provide minimum length, maximum surface area ground conductors. If a leadwire is required, use 14 AWG copper wire.</li> <li>3. Make sure that mechanically tightened joints along the ground path are free of nonconductive coatings and protected against corrosion on mating surfaces.</li> </ol>
Signal ground (Keyboard Display Module, Data ControlBus™ Module, Communications Interface ControlBus™ Module).	Use the shield of the signal wire to ground the device to the signal ground terminal 3(c) of each device. Connect the shield at both ends of the daisy chain to earth ground.

7. Recommended wire routing of leadwires:
  - a. Do not run high voltage ignition transformer wires in the same conduit with the flame detector, Data ControlBus Module™, or Remote Reset Module wiring.
  - b. Do not route flame detector, Data ControlBus™ Module, or Remote Reset Module leadwires in conduit with line voltage circuits.
  - c. Enclose flame detector leadwires without armor cable in metal cable or conduit.
  - d. Follow directions in flame detector, Data ControlBus™ Module, or Remote Reset Module Instructions.
8. The KDM is powered from a low voltage, energy limited source. It can be mounted outside of a control panel if it is protected from mechanical damage.
9. Remote Reset leadwires: The maximum length of wire is 1000 feet (305 meters) to a Remote Reset pushbutton.
10. Data ControlBus Module™: The maximum Data ControlBus™ Module cable length depends on the number of system modules connected, the noise conditions and the cable used. The maximum length of all Data ControlBus™ Module interconnecting wire is 4000 feet (1219 meters).
10. Be sure loads do not exceed the terminal ratings. Refer to the label on the RM7895A,B,C,D/EC7895A,C; RM7896A,B,C,D or to the terminal ratings in Table 3.

## Final Wiring Check

1. Check the power supply circuit. The voltage and frequency tolerance must match those of the RM7895A,B,C,D/EC7895A,C; RM7896A,B,C,D. A separate power supply circuit can be required for the RM7895A,B,C,D/EC7895A,C; RM7896A,B,C,D. Add the required disconnect means and overload protection.
2. Check all wiring circuits and complete Static Checkout in Table 6 before installing the RM7895A,B,C,D/EC7895A,C; RM7896A,B,C,D on the subbase.
3. Install all electrical connectors.
4. Restore power to the panel.

NOTE: A 13 Vdc power supply must be used any time more than one KDM is used.

- a. RM7895A,B,C,D/EC7895A,C; RM7896A,B,C,D leadwires: The maximum leadwire length is 300 feet to terminal inputs (Control, Running/Lockout Interlock).
- b. Flame Detector leadwires: The maximum flame sensor leadwire length is limited by the flame signal strength.

**Table 3. Terminal Ratings.**

Terminal Number	Description	Ratings	
		RM7895/RM7896	EC7895
G	Flame Sensor Ground	—	—
Earth G	Earth Ground <sup>a</sup>	—	—
L2(N)	Line Voltage Common	—	—
3	Alarm	120 Vac, 1A pilot duty.	220-240 Vac, 1A pilot duty.
4	Burner Motor	120 Vac, 9.8A AFL, 58.8 ALR (inrush).	220-240 Vac, 4A at PF = 0.5, 20A inrush.
5	Line Voltage Supply (L1)	120 Vac (+10/-15%), 50 or 60 Hz (±10%). <sup>b</sup>	220-240 Vac (+10/-15%), 50 or 60 Hz (±10%).
6	Burner Controller and Limits	120 Vac, 1 mA.	220-240 Vac, 1 mA.
7	Lockout Interlock	120 Vac, 8A run, 43A inrush.	8A at PF = 0.5, 40A inrush, 2A at PF = 0.2.
8	Pilot Valve/Ignition	120 Vac <sup>c</sup>	220-240 Vac, 4A at PF = 0.5, 20A inrush.
9	Main Fuel Valve	120 Vac <sup>c</sup>	220-240 Vac, 4A at PF = 0.5, 20A inrush.
10	Ignition	120 Vac <sup>c</sup>	220-240 Vac, 2A at PF = 0.2
F(11)	Flame Sensor	60 to 220 Vac, current limited.	60 to 220 Vac, current limited.
12 to 20	Unused	—	—
21	2nd Stage Main Valve (EC7895C, RM7895C,D; RM7896C,D)	120 Vac <sup>c</sup>	220-240 Vac, 4A at PF = 0.5, 20A inrush.
22	Shutter	120 Vac, 0.5A	220-240 Vac <sup>d</sup>

<sup>a</sup> See Table 2.

<sup>b</sup> 2000 VA maximum load connected to RM7895A,B,C,D/EC7895A,C/RM7896A,B,C,D Assembly.

<sup>c</sup> See Tables 4 and 5.

<sup>d</sup> Requires 220-240 Vac, 10 VA minimum, stepdown transformer to operate the shutter.

**Table 4. Combinations for Terminals 8, 9, 10 and 21.**

Combination Number	Pilot Fuel 8	Main 9	Ignition 10	Delayed Main Valve 21
1	C	F	No Load	No Load
2	B	F	No Load	No Load
3	F <sup>a</sup>	No Load	A	No Load
4	F	F	A	No Load
5	F <sup>a</sup>	No Load	A	F
6	D	F	A	No Load
7	D <sup>a</sup>	No Load	A	D
8	D	D	A	No Load
9	D <sup>a</sup>	No Load	A	D

<sup>a</sup> RM7895C,D: EC7895C, RM7896C,D only, jumper terminals 8 to 9.

**Table 5. Composition of each Combination.**

A	B	C	D	F
4.5A ignition	50 VA Pilot Duty <sup>a</sup> plus 4.5A ignition.	180 VA Ignition plus motor valves with: 660 VA inrush, 360 VA open, 240 VA hold.	2A Pilot Duty. <sup>a</sup>	65 VA Pilot Duty <sup>a</sup> plus motor valves with: 3850 VA inrush, 700 VA open, 250 VA hold.

<sup>a</sup> Pilot Duty refers to solenoid-type valves.

## STATIC CHECKOUT

After checking all wiring, perform this checkout before installing the EC7895A,C/RM7895A,B,C,D/RM7896A,B,C,D on the subbase. These tests verify the Q7800 Wiring Subbase is wired correctly, and the external controllers, limits, interlocks, actuators, valves, transformers, motors and other devices are operating properly.

### WARNING

**Fire or Explosion Hazard.**  
**Can cause property damage, severe injury or death.**

Close all manual fuel shutoff valve(s) before starting these tests.

Use extreme care while testing the system. Line voltage is present on most terminal connections when power is on.

Ensure proper selection of configuration jumpers before starting the burner operation.

### CAUTION

**Electrical Hazard.**  
**Can cause equipment damage or failure.**  
Do not perform a dielectric test with the relay module installed. Internal surge protectors can break down, allowing relay module to fail the dielectric test and destroy the internal lightning and high current protection.

1. Open the master switch before installing or removing a jumper on the subbase.
2. Before continuing to the next test, be sure to remove the test jumper(s) used in the previous test.
3. Replace all limits and interlocks that are not operating properly. Do not bypass limits and interlocks.

## Equipment Recommended

1. Voltmeter (1M ohm/volt minimum sensitivity) set on the 0 to 300 Vac scale.
2. Two jumper wires, no. 14 wire, insulated, 12 in. (304.8 mm) long with insulated alligator clips at both ends.

## General Instructions

1. Perform all applicable tests listed in Static Checkout, Table 6, in the order listed.
2. Make sure all manual fuel shutoff valve(s) are closed.
3. For each test, open the master switch and install the jumper wire(s) between the subbase wiring terminals listed in the Test Jumpers column.
4. Close the master switch before observing operation.
5. Read the voltage between the subbase wiring terminals listed in the Voltmeter column.
6. If there is no voltage or the operation is abnormal, check the circuits and external devices as described in the last column.
7. Check all wiring for correct connections, tight terminal screws, correct wire, and proper wiring techniques. Replace all damaged or incorrectly sized wires.
8. Replace faulty controllers, limits, interlocks, actuators, valves, transformers, motors and other devices, as required.
9. Make sure normal operation is obtained for each required test before continuing the checkout.
10. After completing each test, be sure to open the master power switch and remove the test jumper(s) before proceeding to the next test.

### WARNING

**Explosion hazard.**  
**Can cause serious injury or death.**  
Be sure all manual fuel shutoff valves are closed.

Table 6. Static Checkout .

Test Number	Relay Module Model	Test Jumpers	Voltmeter	Normal Operation	If Operation is Abnormal, Check Items Listed Below
1	All	None	5-L2	Line voltage at terminal 5.	1. Master switch. 2. Power connected to master switch. 3. Overload protection (fuse, circuit breaker, etc.) has not opened power line.
2	All	None	6-L2	Line voltage at terminal 6.	1. Limits. 2. Burner controller.
3	All	4-5	7-L2	1. Burner motor (fan or blower) starts. 2. Line voltage at terminal 7 within 10 seconds.	1. Burner motor circuit. a. Manual switch of burner motor. b. Burner motor power supply, overload protection and starter. c. Burner motor.
4	All	5-10	—	1. Ignition spark (if ignition transformer is connected to terminal 10).	1. Watch for spark or listen for buzz. a. Ignition electrodes are clean. b. Ignition transformer is okay.

**Table 6. Static Checkout (Continued).**

Test Number	Relay Module Model	Test Jumpers	Voltmeter	Normal Operation	If Operation is Abnormal, Check Items Listed Below
5	All	5-8	—	1. Ignition spark (if ignition transformer is connected to terminal 8). 2. Automatic pilot valve opens (if connected to terminal 8).  NOTE: Refer to wiring diagram of system being tested.	1. Watch for spark or listen for buzz. 2. Listen for click or feel head of valve for activation. a. Actuator if used. b. Pilot valve.
6	All	5-9	—	Automatic fuel valve(s) open(s). If using direct spark ignition, check first stage fuel valve(s) instead of pilot valve.	Same as test 5. If using direct spark ignition, check first stage fuel valve(s) instead of pilot valve.
7	EC7895C; RM7895C,D; RM7896C,D	5-21	—	Automatic second stage main fuel valve(s) open(s).	1. Listen for and observe operation of second stage main fuel valve(s) and actuator(s). 2. Valve(s) and actuator(s).
8	All	5-3	—	Alarm (if used) turns on.	1. Alarm.
Final	All	 <b>CAUTION</b> <b>Equipment Damage Hazard.</b> <b>Can cause equipment damage.</b> After completing these tests, open master switch and remove all test jumpers from subbase terminals. Also remove bypass jumpers, if used, from low fuel pressure limits.			

### Mounting RM7895A,B,C,D/EC7895A,C; RM7896A,B,C,D Relay Module

1. Mount the RM7895A,B,C,D/EC7895A,C; RM7896A,B,C,D vertically on the Q7800 Subbase or mount horizontally with the knife blade terminals pointing down. When mounted on the Q7800A, the RM7895A,B,C,D/EC7895A,C; RM7896A,B,C,D must be in an electrical enclosure.
2. When mounting in an electrical enclosure, provide adequate clearance for servicing, installation and removal of the RM7895A,B,C,D/EC7895A,C; RM7896A,B,C,D, KDM, flame amplifier, flame amplifier signal voltage probes, electrical signal voltage probes and electrical connections.
  - a. Allow an additional two inches (51 mm) below the RM7895A,B,C,D/EC7895A,C; RM7896A,B,C,D for the flame amplifier mounting.
  - b. Allow an optional three-inch (76 mm) minimum on both sides of the RM7895A,B,C,D/EC7895A,C; RM7896A,B,C,D for electrical signal voltage probes.
3. Make sure no subbase wiring is projecting beyond the terminal blocks. Tuck in wiring against the back of the subbase so it does not interfere with the knife blade terminals or bifurcated contacts.

**IMPORTANT**

*The RM7895A,B,C,D/EC7895A,C; RM7896A,B,C,D must be installed with a plug-in motion rather than a hinge action.*

4. Mount the RM7895A,B,C,D/EC7895A,C; RM7896A,B,C,D by aligning the four L-shaped corner guides and knife blade terminals with the bifurcated contacts on the wiring subbase and securely tightening the two screws without deforming the plastic.

### Mounting Other System Components (Fig. 4)

Refer to the applicable specifications for mounting other system components.

## PRINCIPAL TECHNICAL FEATURES

The RM7895 provides all customary flame safeguard functions as well as significant advancements in safety, annunciation, and system diagnostics.

### Safety Shutdown (Lockout) Occurs if:

1. INITIATE PERIOD
  - a. Purge card is not installed or removed.
  - b. Purge card is bad.
  - c. Configuration jumpers have been changed (after 200 hours)—Fault Code 110.
  - d. AC line power errors occurred, see Operation.
  - e. Four minute INITIATE period has been exceeded.

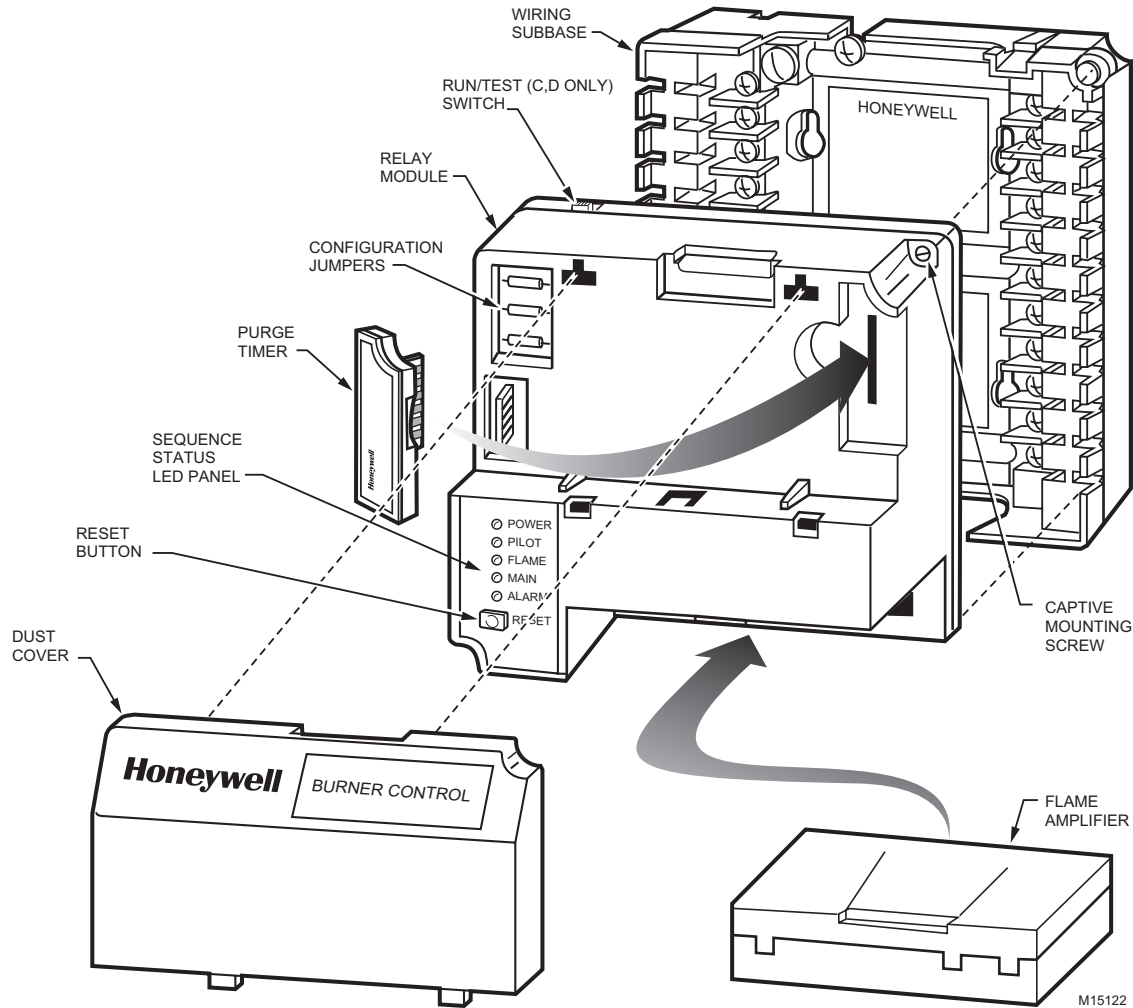

Fig. 4. RM7895A,B,C,D/EC7895A,C; RM7896A,B,C,D Relay Module, exploded view.

**2. STANDBY PERIOD**

- a. Airflow lockout feature is enabled and the airflow switch does not close after ten seconds or within the specified purge card timing.
- b. Flame signal is detected after 30 seconds.
- c. Ignition/pilot valve/intermittent pilot valve terminal is energized.
- d. Main valve terminal is energized.
- e. Delayed main valve terminal is energized (RM7895C,D).
- f. Internal system fault occurred.
- g. Purge card is removed.
- h. Purge card is bad.

**3. PREPURGE PERIOD**

- a. Airflow lockout feature is enabled and the airflow switch opens.
- b. Ignition/pilot valve terminal is energized.
- c. Main valve terminal is energized.
- d. Delayed main valve terminal is energized (RM7895C,D).
- e. Internal system fault occurred.

- f. Purge card is removed.
- g. Purge card is bad.
- h. Flame signal is detected.

**4. PILOT FLAME ESTABLISHING PERIOD (PFEP)**

- a. Airflow lockout feature is enabled and the airflow switch opens.
- b. No flame signal at end of PFEP.
- c. Ignition/pilot valve/intermittent pilot valve terminal is not energized.

**NOTE:** For the RM7895C1020 and RM7896C1036, during the first 8 seconds of PFEP, when a flame signal is detected, terminal 10 is de-energized. If the flame signal is lost, terminal 10 will re-energize.

- d. Main valve terminal is energized.
- e. Delayed (second stage) main valve terminal is energized (RM7895C,D/EC7895C; RM7896C,D).
- f. Internal system fault occurred.
- g. Purge card is removed.
- h. Purge card is bad.

5. MAIN FLAME ESTABLISHING PERIOD (MFEP) (RM7895C, RM7896C,D; EC7895C)
  - a. Airflow lockout feature is enabled and the airflow switch opens.
  - b. Ignition terminal is energized.
  - c. Ignition/pilot valve terminal is not energized.
  - d. Main valve terminal is not energized.
  - e. Delayed main valve terminal is energized.
  - f. No flame signal at end of Flame Failure Response Time.
  - g. Internal system fault occurred.
  - h. Purge card is removed.
  - i. Purge card is bad.
6. RUN PERIOD
  - a. No flame present.
  - b. Airflow lockout feature is enabled and the airflow switch opens.
  - c. Interrupted pilot valve terminal is energized (RM7895C, RM7896C,D; EC7895C).
  - d. Main valve terminal is not energized.
  - e. Delayed main valve terminal is not energized (RM7895C, RM7896C,D; EC7895C).
  - f. Internal system fault occurred.
  - g. Purge card is removed.
  - h. Purge card is bad.
  - i. Ignition terminal is energized.

## OPERATION

### Sequence of Operation

The RM7895A,B,C,D/EC7895A,C; RM7896A,B,C,D has the operating sequences listed below; see Fig. 2 and 3. The RM7895A,B,C,D/EC7895A,C; RM7896A,B,C,D LED provide positive visual indication of the program sequence: POWER, PILOT, FLAME, MAIN and ALARM.

### Initiate

The EC7895A,C/RM7895A,B,C,D;RM7896A,B,C,D Relay Module enters the INITIATE sequence when the relay module is powered. The EC7895A,C/RM7895A,B,C,D; RM7896A,B,C,D can also enter the INITIATE sequence if the relay module verifies voltage fluctuations of +10/-15% or frequency fluctuations of  $\pm 10\%$  during any part of the operating sequence. The INITIATE sequence lasts for ten seconds unless the voltage or frequency tolerances are not met. When not met, a hold condition is initiated and displayed on the optional KDM for at least five seconds; when met, the INITIATE sequence restarts. If the condition is not corrected and the hold condition exists for four minutes, the EC7895A,C/RM7895A,B,C,D; RM7896A,B,C,D locks out. Causes for hold conditions in the INITIATE sequence:

1. AC line dropout detection.
2. AC line noise that can prevent a sufficient reading of the line voltage inputs.
3. Low line voltage brownouts.

The INITIATE sequence also delays the burner motor starter from being energized and de-energized from an intermittent AC line input or control input.

### Standby

The EC7895A,C/RM7895A,B,C,D;RM7896A,B,C,D is ready to start an operating sequence when the operating control input determines a call for heat is present. The burner switch, limits, operating limit control and all microcomputer-monitored circuits must be in the correct state for the relay module to continue into the PREPURGE sequence.

### Normal Start-Up Prepurge

The EC7895A,C/RM7895A,B,C,D/RM7896A,B,C,D Relay Module provides PREPURGE timing selectable from two seconds to thirty minutes with power applied and the operating control indicating a call for heat.

1. The Airflow Interlock, burner switch, Run/Test switch and all microcomputer-monitored circuits must also be in the correct operating state.
2. The motor output, terminal 4, is powered to start the PREPURGE sequence.
3. The Airflow Interlock input closes ten seconds into PREPURGE or within the specified purge card timing; otherwise, a recycle to the beginning of PREPURGE or lockout occurs, depending on how the Airflow Switch selectable jumper (JR3) is configured.

### Ignition Trials

1. Pilot Flame Establishing Period (PFEP):
  - a. When the PFEP begins:
    - (1) The pilot valve and ignition transformer, terminals 8 and 10, are energized. The EC7895A, RM7895A,B, and RM7896A,B have an intermittent pilot valve, terminal 8. The EC7895C, RM7895C,D, and RM7896C,D have an interrupted pilot valve, terminal 8.
    - (2) Flame must be proven by the end of the ten second PFEP (four seconds if Configuration Jumper JR1 is clipped) to allow the sequence to continue. If a flame is not proven by the end of PFEP, a safety shutdown occurs.
  - b. With flame proven, the ignition, terminal 10, is de-energized.

NOTE: For the RM7895C1020 and RM7896C1036, during the first 8 seconds of PFEP, when a flame signal is detected, terminal 10 is de-energized. If the flame signal is lost, terminal 10 will re-energize.

2. Main Flame Establishing Period (MFEP):
  - a. After PFEP, and with the presence of flame, the main fuel valve, terminal 9, is powered. If a flameout occurs, the relay module locks out or recycles (depending on status of jumper JR2) within 0.8 or 3 seconds, depending on the Flame Failure Response Time (FFRT) of the amplifier.
  - b. The EC7895C, RM7895C,D and RM7896C,D have a ten second MFEP. After the Ignition Trials, the pilot valve, terminal 8, is de-energized. If a flameout occurs, the relay module locks out or recycles (depending on status of jumper JR2) within 0.8 or 3 seconds, depending on the Flame Failure Response Time (FFRT) of the amplifier.

**Run**

1. The EC7895C, RM7895C,D, RM7896C,D has a delayed main valve that is energized once the RUN period is entered.
2. The relay module is now in RUN and remains in RUN until the controller input, terminal 6, opens, indicating that the demand is satisfied or a limit has opened.

**Post Purge (RM7896A,B,C,D Only)**

After demand is satisfied or a limit opens, de-energizing terminal 6, the Ignition/Pilot valve, main valve and delayed main valve, terminals 8, 9 and 21, are de-energized. The blower motor, terminal 4, remains powered for 15 seconds.

**Run/Test Switch (RM/EC7895C,D; RM7896C,D only)**

The Run/Test Switch is located on the top side of the relay module, see Fig. 5. The Run/Test Switch allows the burner sequence to be altered as follows:

1. In the measured PREPURGE sequence, the Run/Test Switch, placed in the TEST position, causes the PREPURGE timing to stop.
2. In the Pilot Flame Establishing Period, the Run/Test Switch, placed in the TEST position, stops the timer during the first eight seconds of a ten-second PFEP selection or during the first three seconds of a four-second PFEP selection. It also allows for pilot turn-down test and other burner adjustments. This activates a fifteen-second flameout timer that permits pilot flame adjustment without nuisance safety shutdowns. The Run/Test Switch is ignored during PFEP for the C and D relay modules if terminals 8 and 9 or 9 and 21 are jumpered.

**IMPORTANT**

*When the relay module is switched to the TEST mode, it stops and holds at the next Run/Test Switch point in the operating sequence. Make sure that the Run/Test Switch is in the RUN position before leaving the installation.*

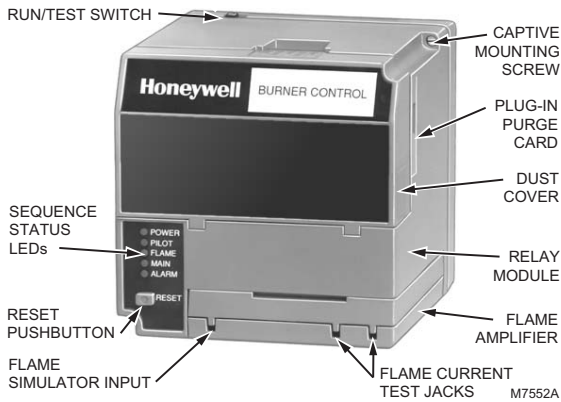

**Fig. 5. Sequence Status LEDs.**

**SETTINGS AND ADJUSTMENTS**

**Selectable Site-Configurable Jumpers**

The relay module has three site-configurable jumper options, see Fig. 6 and Table 6. If necessary, clip the site-configurable jumpers with side cutters and remove the resistors from the relay module.

**SERVICE NOTE:** Clipping and removing a site-configurable jumper enhances the level of safety.

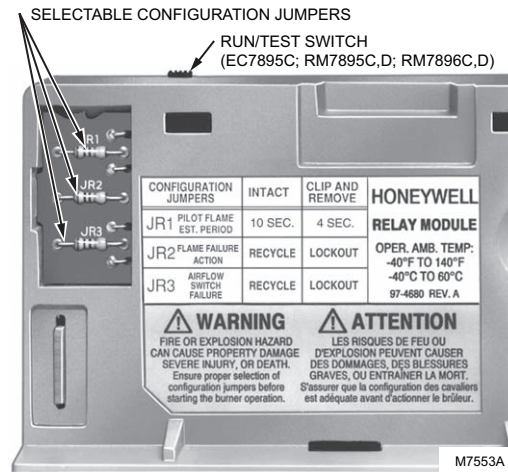

**Fig. 6. Selectable site-configurable jumpers.**

**Table 7. Site-configurable jumper options.**

Jumper Number	Description	Intact	Clipped
JR1 <sup>a, b</sup>	Pilot Flame Establishing Period (PFEP)	10 seconds	4 seconds
JR2 <sup>c</sup>	Flame Failure Action	Recycle	Lockout
JR3	Airflow Switch (ILK) Failure	Recycle	Lockout

- The RM7895C1020 and RM7896C1036 have fixed PFEP of ten seconds and do not have jumper JR1 (3 seconds software revision 4151 or greater).
- The RM7895C1053 has fixed PFEP of four seconds and does not have jumper JR1.
- The RM7895C1053 locks out on Flame Failure Action and does not have jumper JR2.

**IMPORTANT**

*Clipping and removing a jumper after 200 hours of operation causes a nonresettable Fault 110. The relay module must then be replaced.*

**Automation and Control Solutions**

Honeywell International Inc.  
1985 Douglas Drive North  
Golden Valley, MN 55422  
customer.honeywell.com

Honeywell Limited-Honeywell Limitée  
35 Dynamic Drive  
Toronto, Ontario M1V 4Z9

