

# 120 VAC SYSTEM CONTROL KIT

Designed for use on SWG Series Power Vent Hoods for controlling oil fired heating appliances with 120 VAC controls.

The CK-63 control has the ability to operate the oil burner motor (up to 1/3 HP) and the venter at the same time. This allows for shorter post purge time. This feature requires the burner to be equipped with a delayed oil solenoid valve, which is not supplied with this kit.

**Model: CK-63**



#### ITEMS INCLUDED IN KIT:

- 1) Junction box with mounted pressure switch solid state post purge control
- 1) 2 Ft. Length of ¼ inch aluminum tubing
- 1) ¼ inch tubing connector
- 1) Flexible conduit connector
- 1) WMO-1 Blocked Vent Switch

**This device MUST be installed by a qualified agency\* in accordance with the manufacturer's installation instructions.** The definition of a qualified agency is: *any individual, firm, corporation or company which either in person or through a representative is engaged in, and is responsible for, the installation and operation of oil appliances, who is experienced in such work, familiar with all the precautions required, and has complied with all the requirements of the authority having jurisdiction.*

**WARNING:** Read the installation instructions carefully and completely before proceeding with the installation.

- All wiring shall be in accordance with the **National Electrical Code** and applicable local codes.

**DO NOT DESTROY**

THESE INSTRUCTIONS MUST REMAIN WITH EQUIPMENT



**FIELD CONTROLS**

**The Venting Solutions Company™**

## INSTALLATION

### MOUNTING JUNCTION BOX

The junction box can be mounted at the venter or remotely mounted away from the venter. (See Figure 1 & Figure 2)

1. Remove one of the knockouts from the side of the junction box where the pressure switch is mounted. Install the flexible conduit connector onto the CK-63 Junction Box and secure with fastening nut. If remote mounting the CK-63 Junction Box, mount the flexible conduit connector onto a 2" x 4" installer supplied junction box.
2. Fasten the flexible conduit from the SWG Venter into the conduit connector. Mount the CK-63 Junction box or installer supplied junction box onto the wall or floor joist without straining the flexible conduit. Fasten the CK-63 Junction Box through the four dimpled locations on the base of the box. (See Figure 3)

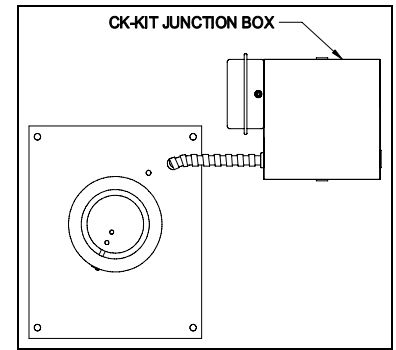

Figure 1

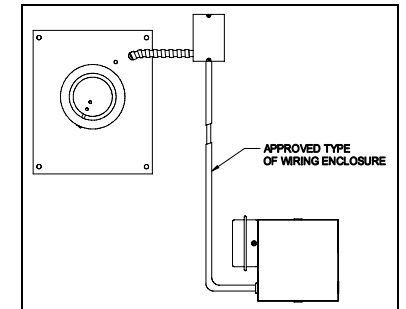

Figure 2

### OIL FIRED SECONDARY SAFETY SWITCH

Installation of a SECONDARY SAFETY SWITCH is recommended for detecting a blocked flue system and/or inadequate draft.

#### MOUNTING IN THE VENT PIPE

SEE THE APPLIANCE MANUFACTURER'S INSTRUCTIONS FOR THE SPECIFIC LOCATION.  
IF THE APPLIANCE MANUFACTURER DOES NOT SPECIFY A LOCATION, REFER TO FIGURE 5.

1. Drill or pierce a clean hole (about 3/4" diameter) in the vent pipe near the appliance outlet. (See Figure 5)
2. The heat transfer tube must have the fiber gasket installed against the mounting plate before attaching the unit to the vent pipe
3. Insert the heat transfer tube with gasket into the 3/4" diameter hole placed in the vent pipe during step 1.
4. Secure the assembly to the vent pipe with a minimum of 4 sheet metal screws. The channel must be mounted horizontally, unless specified differently by the appliance manufacturer. (See Figure 5)

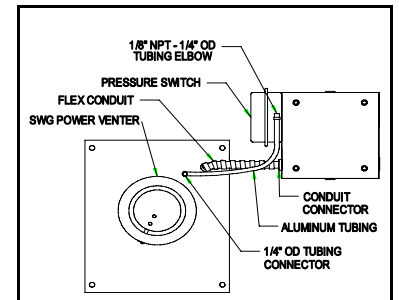

Figure 3



#### **WARNING:**

Switch connection channel must be mounted horizontally, unless specified differently by the appliance manufacturer.



#### **CAUTION:**

Disconnect electrical power supply to the appliance when wiring the blocked vent switch.

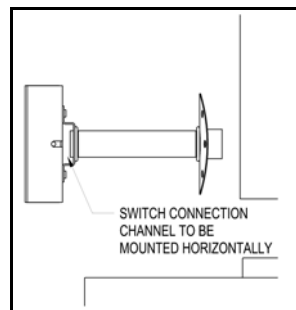

Figure 4

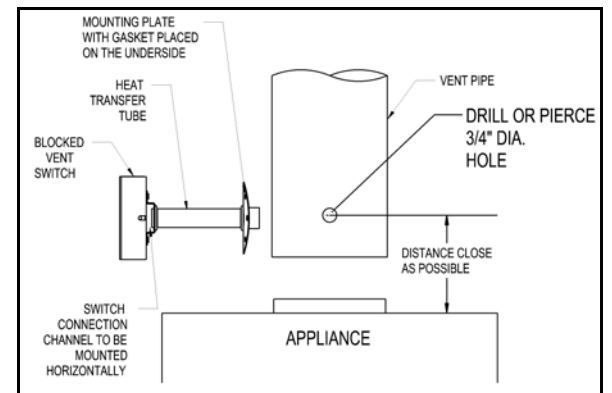

Figure 5

### PRESSURE SWITCH SENSING TUBE INSTALLATION

1. Attach the 1/4 inch tubing connector to the pressure tube on the SWG Venter. (See Figure 3)
2. Connect the supplied 1/4" aluminum tubing to the tubing connector. Route the tubing to the CK-63 Junction Box and connect the tubing to the pressure switch. When routing the tubing avoid kinking the tubing by bending the tubing too sharply.
3. For remote mounted CK-63 Junction Box, use a 1/4" OD copper, aluminum or plastic tubing and route the tubing to avoid contact with any heat source.

Refer to the SWG Venter installation instructions for setting system airflow.



**POLARITY SENSITIVE**

- \*L1 = Hot
- \*L2 = Neutral

**WARNING: Reversed polarity may cause equipment damage!**

- ..... New wire supplied by installer
- 🔗 Solderless connector (wire nut)

- \* L1 is 120V
- \* N is 120V Neutral
- M is 120V if the motor is running
- T1 is 120V if there is a call for heat
- T2 is 120V Neutral
- T3 is 120V if there is a call for heat

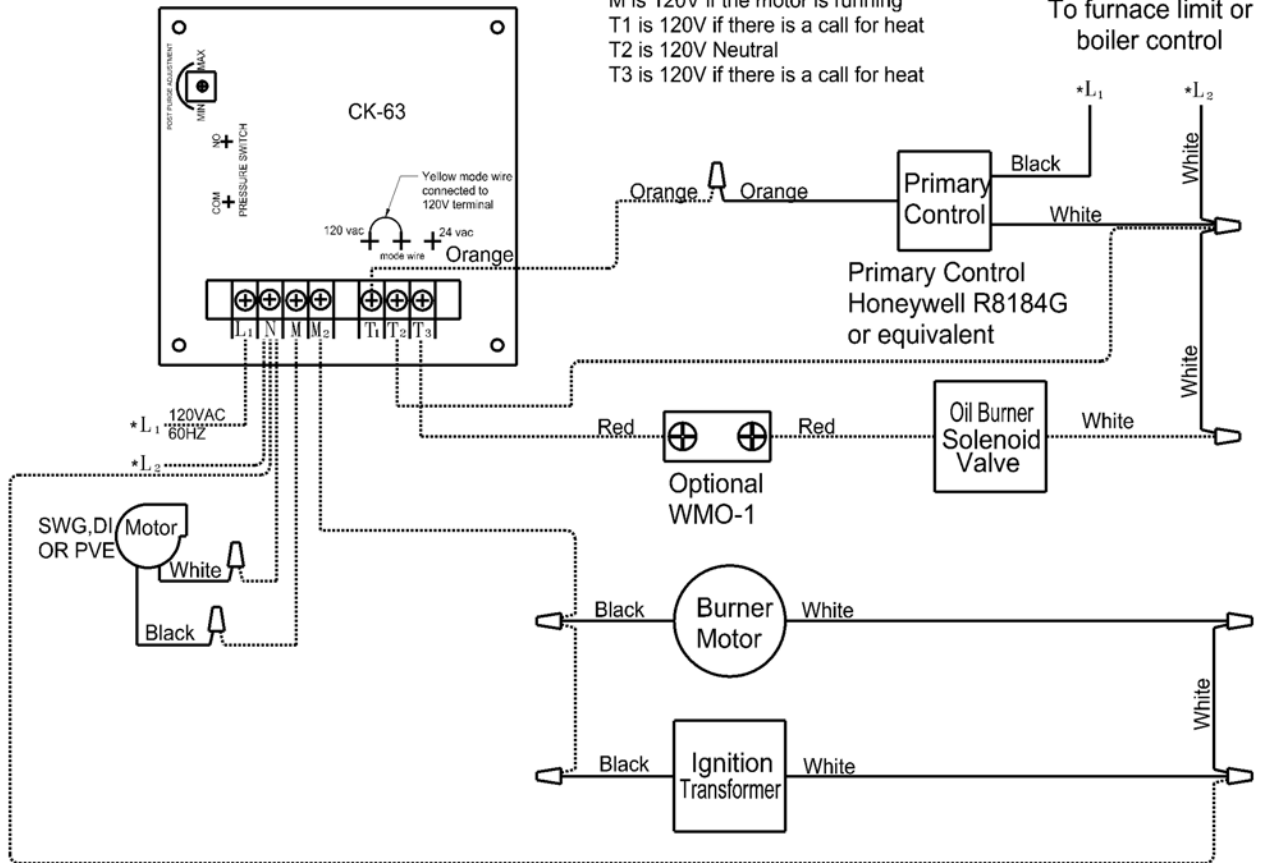

**Diagram B – Oil Fired System: Simultaneous Burner Wiring**

# HONEYWELL R7184B & CARLIN 60200-02

**POLARITY SENSITIVE**

\*L1 = Hot

\*L2 = Neutral

**WARNING: Reversed polarity may cause equipment damage!**

-----New wire supplied by installer

 Solderless connector (wire nut)

\* L1 is 120V

\* N is 120V Neutral

M is 120V if the motor is running

T1 is 120V if there is a call for heat

T2 is 120V Neutral

T3 is 120V if there is a call for heat

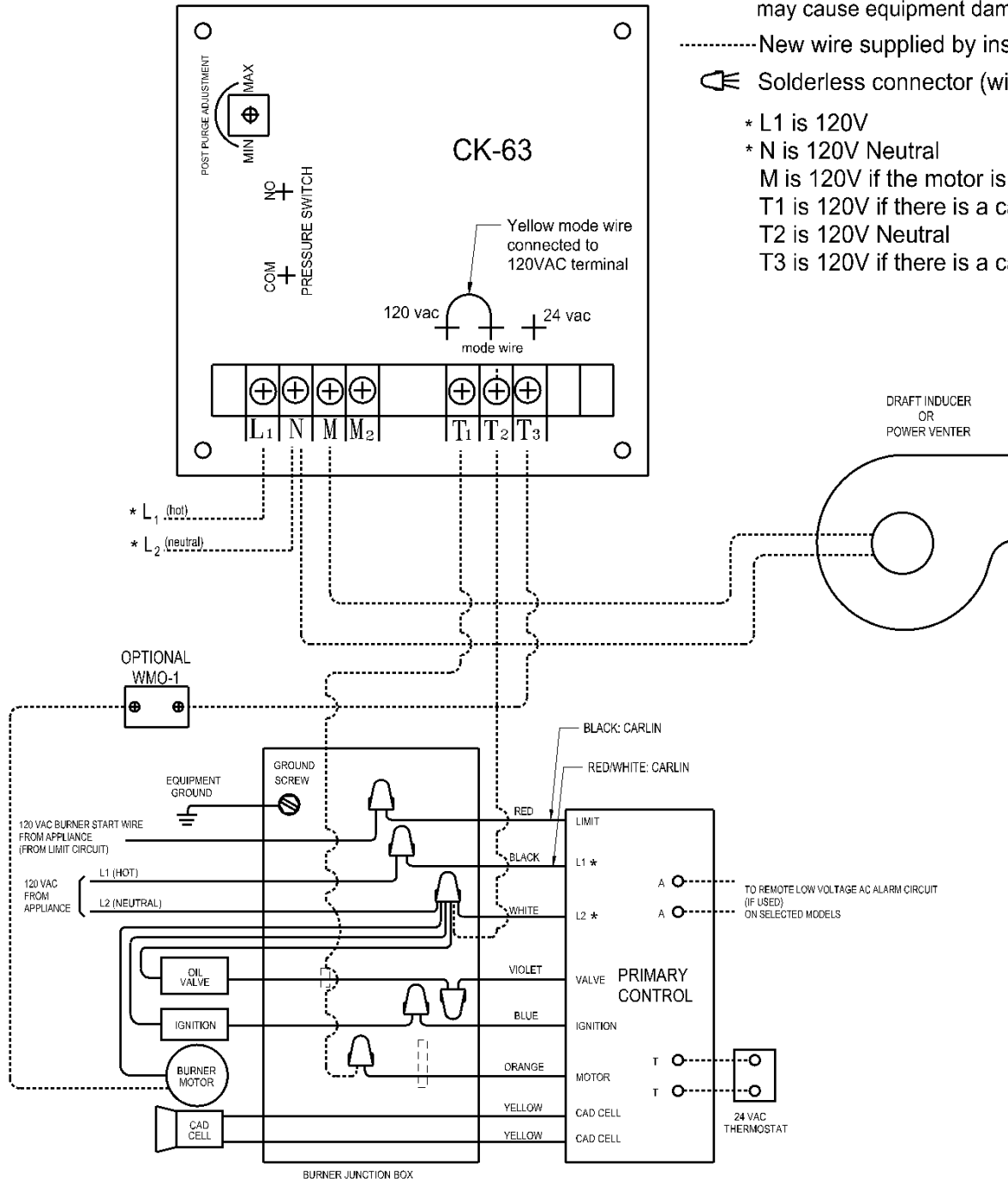

**Diagram C – Oil Fired System: Wiring With Electronic Primary**

# SIMULTANEOUS VENTER/BURNER OPERATION HONEYWELL R7184B & CARLIN 60200-02

POLARITY SENSITIVE

\*L1 = Hot

\*L2 = Neutral

WARNING: Reversed polarity may cause equipment damage!

..... New wire supplied by installer

 Solderless connector (wire nut)

\* L1 is 120V

\* N is 120V Neutral

M is 120V if the motor is running

M2 is 120V if the motor is running

T1 is 120V if there is a call for heat

T2 is 120V Neutral

T3 is 120V if there is a call for heat

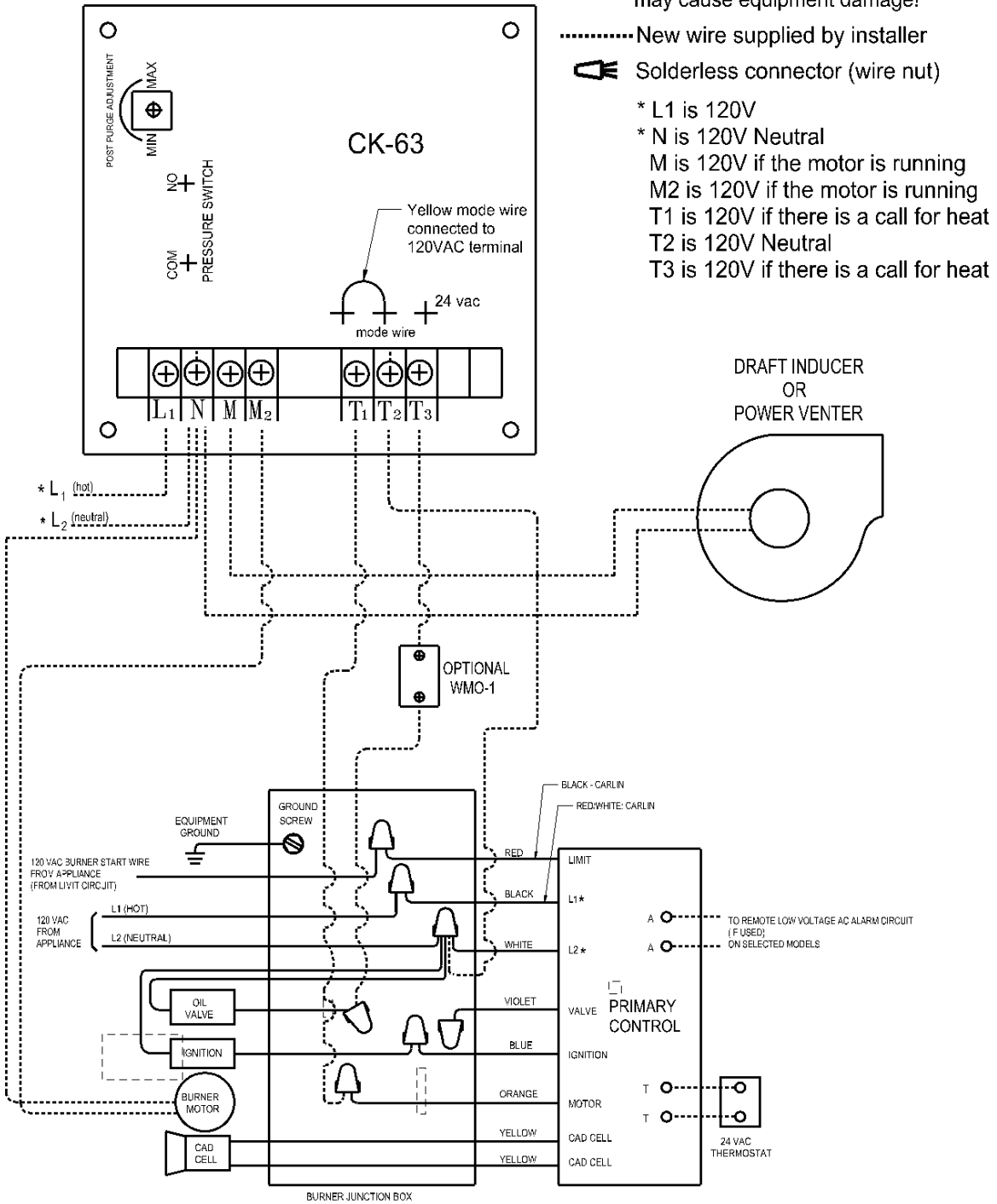

**Diagram D – Oil Fire System: Simultaneous Burner Wiring With Electronic Primary**

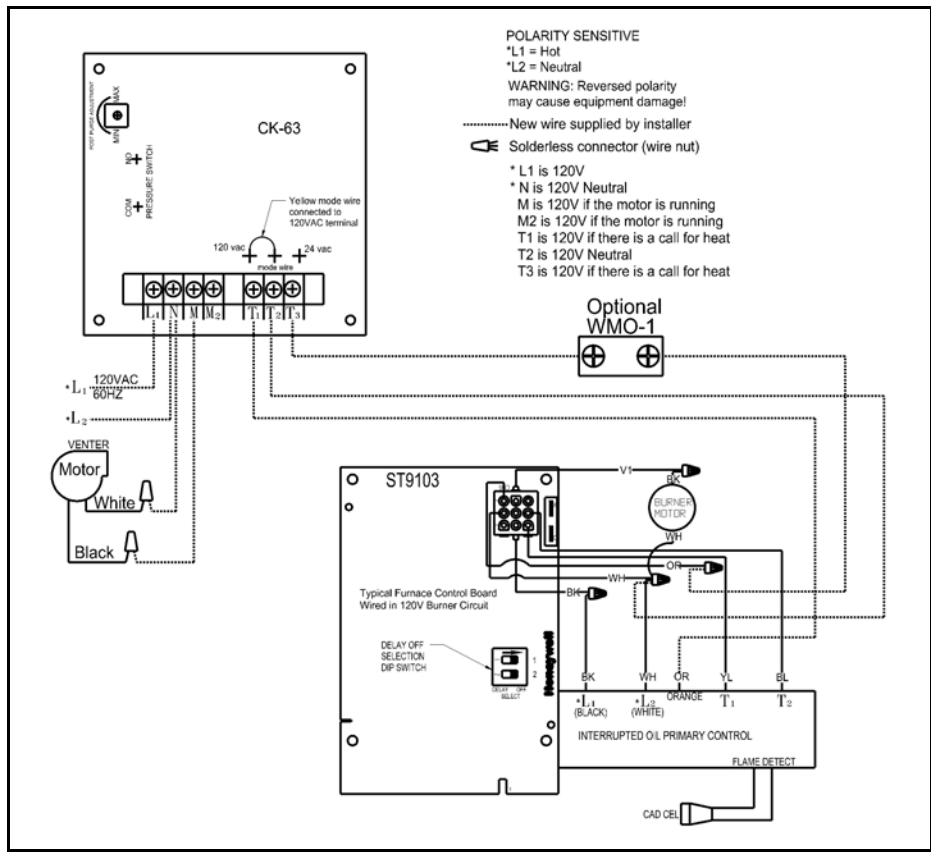

**Diagram E – Typical Wiring for Oil Fired Warm Air Furnace with a Honeywell ST9103 Control Board**

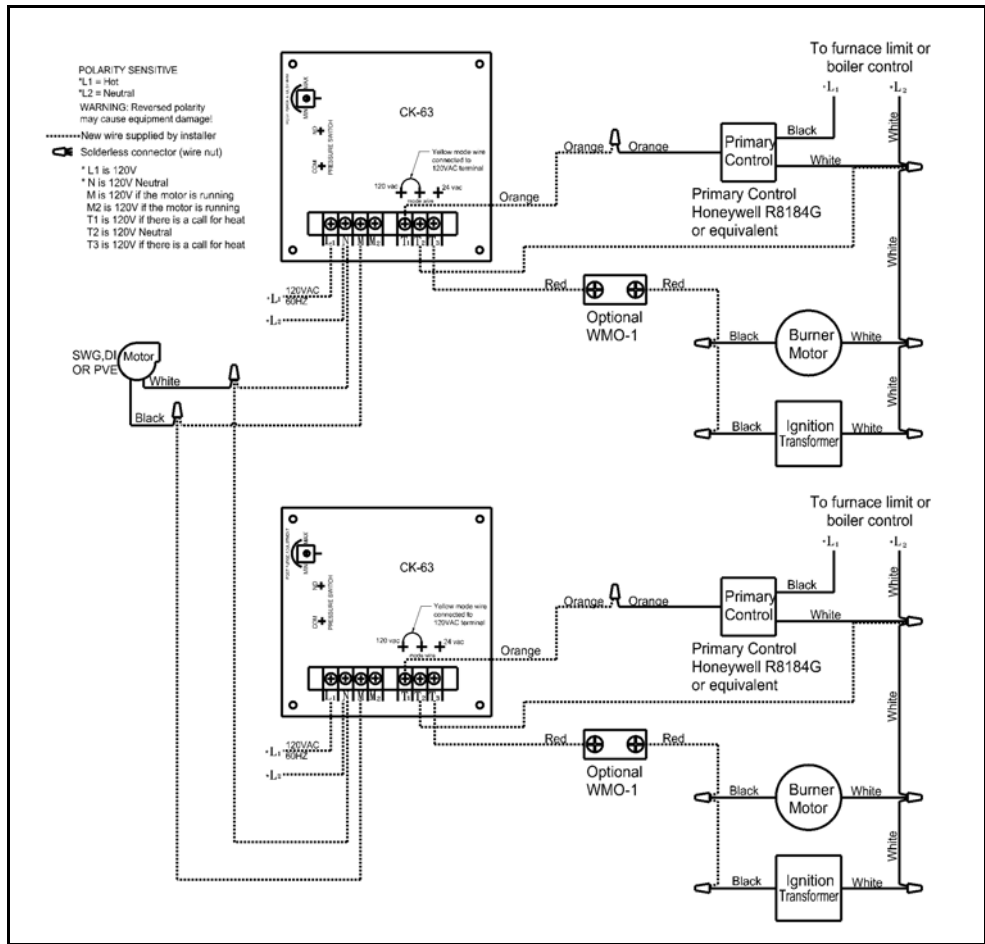

**Diagram F – Multiple Oil Fired Systems**

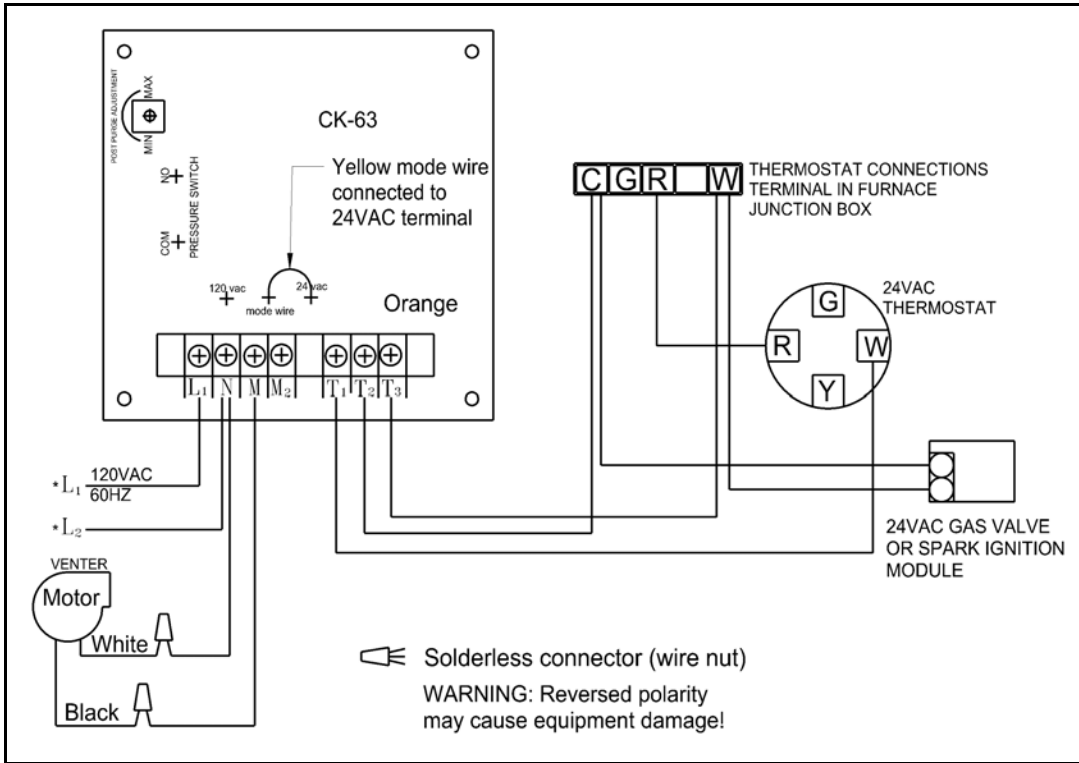

Diagram G-24V Gas Furnace Application

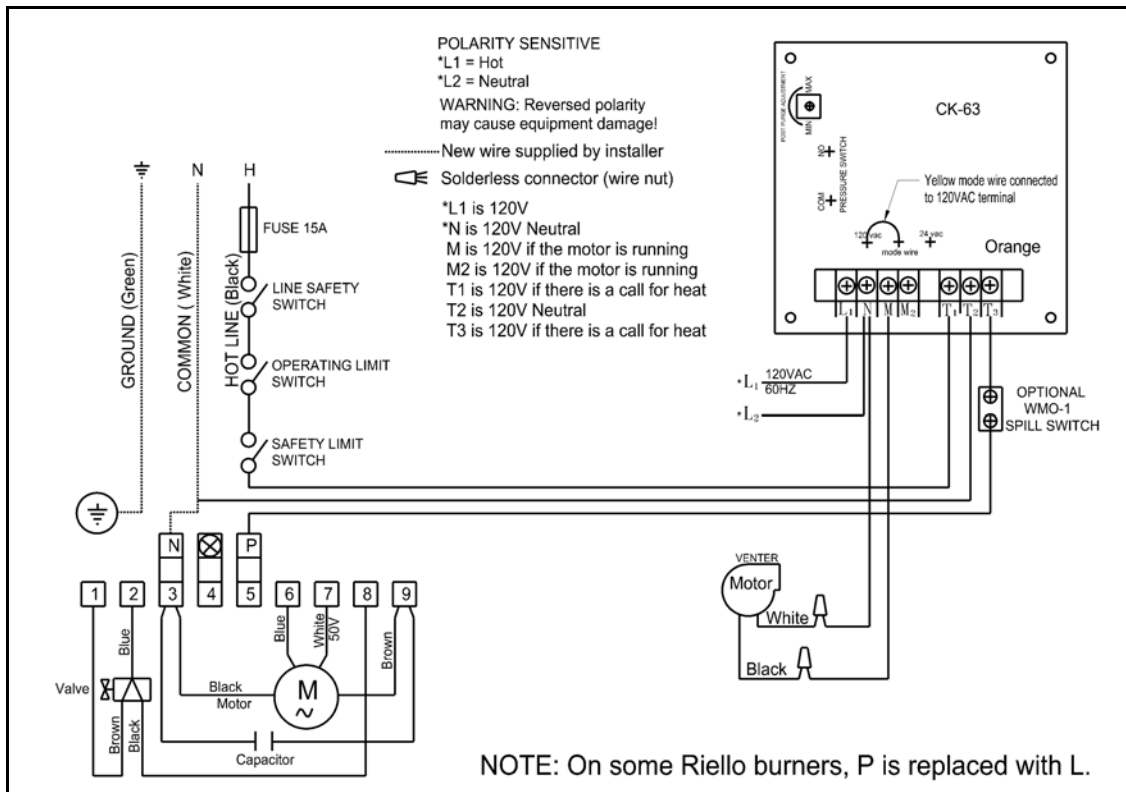

Diagram H-Riello Burner Application

## **ADJUSTMENTS**

### **PRESSURE SWITCH ADJUSTMENTS**

With the venter air flow set and the appliance operating at the best operating efficiency, adjust the pressure switch by rotating the adjustment screw clockwise until the burner shuts off, then rotate the adjustment screw counterclockwise until the burner fires. Rotate the adjustment screw an additional 1/4 to 1/2 turn counterclockwise to ensure proper switch setting. (See Figure 7)

### **POST PURGE TIMING ADJUSTMENT**

To adjust the post purge time, rotate the timer adjustment on the timer clockwise to increase the operation time. To decrease the operation time, rotate the timer adjustment counterclockwise. (See Figure 8) Typical post purge time should be between 3 to 5 minutes. If running burner simultaneous with venter, 1-3 minutes is suggested.

### **SYSTEM CONTROL CHECK OUT PROCEDURES**

1. Adjust the thermostat to call for heat and observe the power venting system for proper operation sequence (Repeat if necessary).
  - a. Thermostat calls for heat.
  - b. Relay is energized and venter motor starts.
  - c. Pressure switch closes and burner starts.  
The LED light indicates power to T3. When the pressure switch closes with a call for heat, the LED light will come on. This indicates that the burner should be in a burn cycle. (See Figure 8)
  - d. Thermostat is satisfied, burner stops and venter motor should operate for the set post purge time. The LED should not be on during the post purge.
2. While system is operating, disconnect power to the venter motor. This should open the pressure switch contacts and stop burner operation.
3. (If WMO-1 switch is installed) Allow vent system to cool. Disconnect the vent pipe between the venter inlet and the appliance outlet. Block the vent pipe with a noncombustible material. Activate the heating system with the main burner operating. Allow approximately 2 minutes or less for the secondary safety switch to deactivate the burner. Reset safety switch after waiting 15 minutes for WMO-1 to cool down and repeat.

### **YEARLY MAINTENANCE PROCEDURE FOR POWER VENTER**

1. Motor: Inspect motor once a year; the motor should rotate freely.
2. Wheel: Inspect venter wheel annually, for oil fired heating systems, clear any soot, ash or coating, which inhibits either rotation or air flow. Remove all foreign material before operating.
3. Vent System: Inspect all vent pipe connections annually for looseness and for evidence of flue gas leakage. Seal or tighten pipe connections if necessary.
4. Lubricate motor with SWG Superlube with 6 drops in each oil port hole annually.

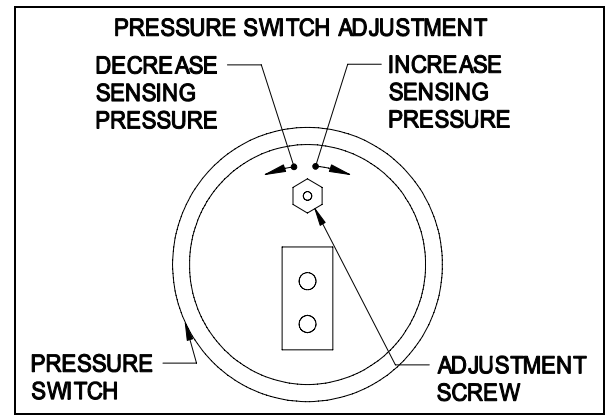

**Figure 7**

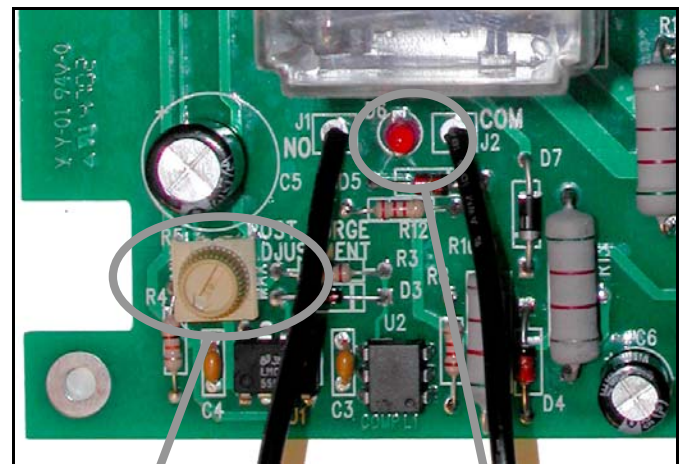
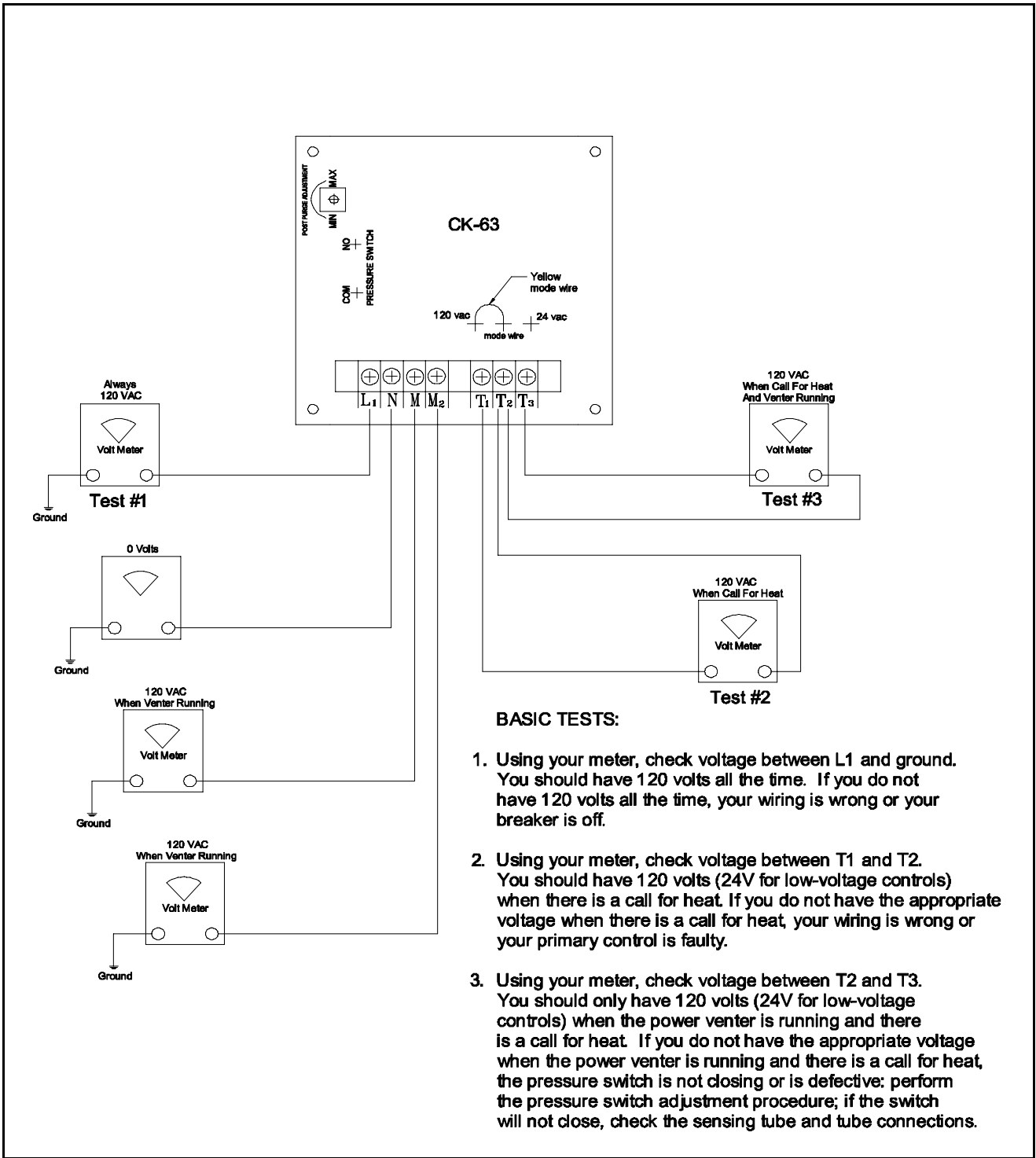

**Figure 8**

## **TROUBLE SHOOTING HINTS**

1. Main burner does not fire when thermostat calls for heat with venter operating.
  - a. Check pressure switch adjustment. (LED should be lit when there is voltage from T1 – T2 and the pressure switch is closed.)
  - b. Check fuel flow.
  - c. Check wiring connections between pressure switch and burner and yellow mode wire connection.
  - d. Check pressure switch for continuity across terminals, during venter operation.
2. Venter does not activate when thermostat calls for heat.
  - a. Jump wire the terminals L1 and M to ensure motor operation.
  - b. Check wiring connections including yellow mode wire.
3. Flue gas odor.
  - a. Check system draft.
  - b. Check post purge venting time.
  - c. Check for negative pressure in building.
4. Power venter cycling.
  - a. Check voltage between T1 and T2 and refer to Wiring Check-Out Standard Set-up (see below).
  - b. Use resistor between T1 (120V) and T2 for bleed voltage.

<b>Replacement Parts List</b>	
<b>Description</b>	<b>Part Number</b>
Pressure Switch	46273100
Board Replacement Kit (includes relay)	46474300
WMO-1	46086900



**BASIC TESTS:**

1. Using your meter, check voltage between L1 and ground. You should have 120 volts all the time. If you do not have 120 volts all the time, your wiring is wrong or your breaker is off.
2. Using your meter, check voltage between T1 and T2. You should have 120 volts (24V for low-voltage controls) when there is a call for heat. If you do not have the appropriate voltage when there is a call for heat, your wiring is wrong or your primary control is faulty.
3. Using your meter, check voltage between T2 and T3. You should only have 120 volts (24V for low-voltage controls) when the power venter is running and there is a call for heat. If you do not have the appropriate voltage when the power venter is running and there is a call for heat, the pressure switch is not closing or is defective; perform the pressure switch adjustment procedure; if the switch will not close, check the sensing tube and tube connections.

**CK-63 Wiring Check-Out  
Standard Set-up**

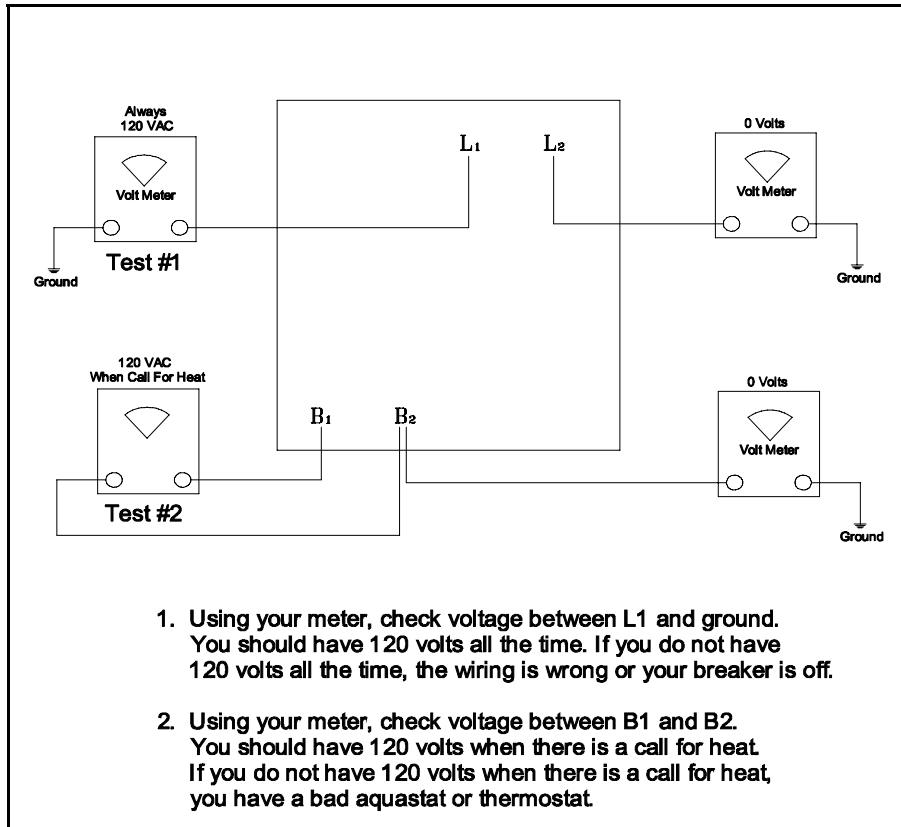

## CK-63 Wiring Aquastat Relay Check-Out

### INSTALLATION INFORMATION

MODEL NO.: CK-63

INSTALLER'S NAME: \_\_\_\_\_

INSTALLER'S COMPANY: \_\_\_\_\_

INSTALLER'S PHONE NO.: \_\_\_\_\_

DATE OF INSTALLATION: \_\_\_\_\_

For Technical Support,  
please call  
1-800-742-VENT



**FIELD CONTROLS**  
The Venting Solutions Company™